



2020 ELDORA SPECIFIC RULES – ALL DIVISIONS

DISCLAIMER

The rules and/or regulations set forth herein are designed to provide for the orderly conduct of racing events and to establish minimum acceptable requirements for such events. These rules shall govern the condition of all events, and by participating in these events, all participants are deemed to have complied with these rules. **NO EXPRESSED OR IMPLIED WARRANTY OF SAFETY SHALL RESULT FROM PUBLICATIONS OF OR COMPLIANCE WITH THESE RULES AND/OR REGULATIONS.** They are intended as a guide for the conduct of the sport, the construction of a racecar and are in no way a guarantee against injury or death to a participant, spectator, or official.

Eldora Speedway, Inc. (Eldora) management shall be empowered to permit reasonable and appropriate deviation from any of the specifications herein or impose any further restrictions that in his/her opinion do not alter the minimum acceptable requirements. **NO EXPRESSED OR IMPLIED WARRANTY OF SAFETY SHALL RESULT FROM SUCH ALTERATION OF SPECIFICATIONS.** Any interpretation or deviation of these rules is left to the discretion of the officials. Their decision is final.

The events will run under Eldora rules and all participants acknowledge that they have received, read and understand all of the rules and regulations associated with the event, and hereby agree to abide by all official Eldora decisions and regulations. Any deviation of these rules and regulations may result in fines or penalties including disqualification from the event.

– ATTENTION ALL PARTICIPANTS –

Eldora Speedway, Inc. (Eldora) has specific rules which may, from time-to-time, differ from the mechanical, safety and technical rules used at your speedway or sanctioning body for the division.

LICENSE, MEMBERSHIP & INSURANCE

All participants competing at Eldora contest at least one event in 2020 utilizing a format differing from their series championship norm, which is either unique to Eldora and/or officiated by Eldora stewards.

An Eldora Membership License (\$20) is mandatory for all drivers and car owners – regardless of division or sanction – and paid back to the team via the designated payee’s first prize check of the season.

Eldora members in good standing – licenses are also available to pit crews – are eligible for up to \$500,000 in catastrophic EXCESS participant accident coverage at Eldora events (in addition to the EXCESS participant accident coverage provided to members in good standing of sanctioning bodies like DIRTcar/WoO (up to \$500,000) and USAC (up to \$200,000). Investing \$279 in the [Competitive Advantage Program](#) provides you with an additional \$500,000 in coverage...plus any other race in the United States.

CLICK HERE FOR ELDORA LICENSE APPLICATION

DRUG FREE SPORT

- Eldora Speedway, Inc., is a DIRTcar-sanctioned speedway and a supporter of World Racing Group’s partnership with the National Center for Drug Free Sport (Drug Free Sport). [Click here to read announcement.](#) Drivers competing in events at Eldora are subject to random drug-testing conducted by Drug Free Sport per the [Random Drug-Testing Policy](#). Please read the [Frequently Asked Questions and Answers](#) for more information.

FREQUENTLY ASKED QUESTIONS

Question: Do I have to buy a new seat to race at Eldora?

Answer: Not necessarily – All of the sanctioning bodies which race at Eldora require full containment seats. If you do not have a “full containment” or have one of the older versions, you should consult with your seat manufacturer and safety supplier to see what up-fit kit(s) are available for your existing full containment seat. In some cases, your seat’s energy absorbing foam may need an upgrade to SFI 45.2 foam or cage-mounted SFI 37.1 certified net(s) may provide the head surround you need. The SFI 39.2 full containment seat was required by the majority of sanctioning bodies beginning in 2019.

The use of a SFI 39.2 certified seat is recommended

Question: What classifies as a “full containment” seat?

Answer: The design shall include comprehensive head surround, shoulder and torso support system, energy impact foam, and removable head foam. Consult with your seat manufacturer and safety equipment manufacturer for questions and recommendations regarding your seat safety system.

Question: Is there a proper way I should mount my seat?

Answer: Yes. Your seats must be mounted to a seat frame that is welded to the racecar frame and/or roll cage structure. Attaching points, angles, and materials for the seat frame and mounting of the seat to the seat frame must be in accordance to the seat manufacturer's instruction. Seat mounting brackets must use properly sized bolts and washers for the hole in the bracket. No oversized holes or slotted holes will be permitted in the bracket per DIRTcar rulebook.

Question: Am I required to wear a SFI 38.1 certified Head and Neck restraint at Eldora?

Answer: Yes. You must also have your helmet correctly connected when you are on the track.

Question: How old can my seat belts be?

Answer: Your seat belts cannot be more than two (2) years of age past the date of manufacture. Your car should be equipped with a minimum of SFI 16.5 or SFI 16.1 approved belts.

Question: What is the on-board fire system required at Eldora in Modifieds and Stocks?

Answer: In 2017, the promoters of Late Model racing’s major national events and sanctioning bodies adopted the SFI 17.1 certified fire suppression system with a minimum of 10-pound bottle and two thermally activated nozzles (one for the fuel cell area and one for the driver). These systems were recommended for Modifieds and Stock Cars at Eldora in 2017. The fire suppression systems became mandatory for all DIRTcar UMP Modifieds and Stock Cars competing at Eldora effective June 1, 2018.

Question: Is the cockpit shut-off switch good enough or should I have one somewhere else on the car?

Answer: There should be a master battery disconnect in the decking behind the driver’s seat. It must be easily accessible from the outside of the racecar for the safety crews. The switch must be clearly labeled with ON/OFF direction. The switch must shut the engine off.

Question: The DIRTcar rules say “...fuel cells constructed to meet or exceed FIA/FT3 or SFI 28.3 standards...” but my fuel cell does not have the hologram or SFI 28.3 on it. How do I know if it is constructed standards?

Answer: Great question! First, as with all safety equipment, call the manufacturer. We know there is an internal aftermarket of used racecars, used parts, swap meets, auctions, etc., and we know things get painted in the off-season, and we know not every fuel cell comes with the FIA hologram – and even if they did, could the hologram last through 30-50 car washes a season? Some elements to look for:

- 1) *The metal container must be constructed of .060 aluminum or 20-gauge steel.*
- 2) *The valve plate on the top will be bolted.*
- 3) *Nothing can vent or connect on the sides of the fuel cell – everything must go through the top and have a “flop/rollover” flap or check-ball valve in case of rollover.*
- 4) *The fuel cap will be threaded (the ATL Part #751 Twist Cap is approved for competition).*
- 5) *Flexible bladder within the container.*
- 6) *Foam within the bladder – in the past, some teams have hulled, removed or stopped using foam altogether.*

Question: How should my ballast be mounted?

Answer: All weights should be mounted with two (2) ½ -inch minimum grade 5 bolts with a minimum of two weight clamps no matter how many pounds. They must be painted white and clearly labeled with the car number on them.

Question: What is the Late Model tire rule at Eldora in 2020?

Answer: The Hoosier LM 20 is required on the Left Front (LF), Right Front (RF) and Left Rear (LR) positions. The LM 20 or Hoosier LM 40 tire is permitted on the Right Rear (RR) position. Tire rule, including alteration of factory compound as manufactured, will be enforced according to DIRTcar rulebook.

Question: Will the DIRTcar/WoO LMS droop rule be in effect at Eldora in 2020?

Answer: Yes. All mechanical and technical rules will be enforced according to DIRTcar rulebook.

SPECIAL RULES FOR OPEN WHEEL CARS

Eldora Speedway, Inc. is a member of the Sprint Car Safety Council.

**SFI 38.1 Head and Neck Restraint required for all drivers (see SAFETY EQUIPMENT – DRIVER below)
Full Containment seats required for all drivers (see SAFETY EQUIPMENT – RACECAR INSTALLED below)**

SPECIAL RULES FOR LATE MODELS, MODIFIEDS AND STOCK CARS

BATTERY AND ELECTRICAL (same as DIRTcar)

- The battery must be securely mounted with positive fasteners and brackets.
- The battery terminals must be insulated or enclosed with a non-conductive material that will prevent contact with any part of the racecar should the battery become dislodged from the battery mount.
- One (1) mandatory battery disconnect switch must be installed on the rear deck, behind the driver seat, in a location that is easily accessible from outside the racecar. The switch must be clearly labeled with off/on direction. The switch must be directly in-line with the NEGATIVE battery cable and be capable of completely disconnecting the NEGATIVE terminal of the battery from the racecar. Negative or "ground" wiring connections must not be made anywhere from the battery negative terminal to the input side of the disconnect switch. An additional battery disconnect switch within the drivers reach may also be used.

CHASSIS, FRAME AND ROLL CAGE – INTRUSION PLATES (same as DIRTcar)**DIRECT WELD – INDIVIDUAL PLATES**

- A minimum 1/8" (.125") thick magnetic steel intrusion plate on the driver's side door bars is mandatory. Individual plates between door bars are permitted but must be welded around the perimeter.

W1. EXTERIOR VIEWW2. INTERIOR VIEW**APPROVED FOR COMPETITION: WELDED TABS/BOLT ON PLATE**

- Minimum 1/8" (.125") thick magnetic steel intrusion plate measuring a minimum of 16" x 26".
- Intrusion plate must be bolted to fabricated 1/8" (.125") magnetic steel tabs, welded securely to the chassis, using a minimum of eight (8) x 3/8" Allen button head bolts.
- A minimum of three (3) fabricated 1/8" (.125") magnetic steel tabs and 3/8" Allen button head bolts required across top of the intrusion plate, a minimum of three (3) fabricated 1/8" (.125") magnetic steel tabs and 3/8" Allen button head bolts required across the bottom of the plate, and one (1) fabricated 1/8" (.125") magnetic steel tabs and 3/8" Allen button head bolt in each in the middle front and middle rear of intrusion plate.

T1. EXTERIOR VIEWT2. INTERIOR VIEW**APPROVED FOR COMPETITION: INDIVIDUAL DOOR BAR CLAMPS/BOLT ON PLATE**

- Minimum 1/8" (.125") thick magnetic steel intrusion plate measuring a minimum of 16" x 26".
- Intrusion plate must be bolted to a minimum of six (6) approved-design door bar clamps using the included 12 x 1/2" Allen button head bolts per the manufacturer's specification.
- A minimum of three (3) approved-design door bar clamps and the included six (6) x 1/2" Allen button head bolts required across top of the intrusion plate and three (3) approved-design door bar clamps and included six (6) x 1/2" Allen button head bolts required across bottom of intrusion plate.
- Vendor and part number must be clearly labeled on part.

Current approved-design door bar clamps (as of June 6, 2017) – in order of submission:

Manufacturer(s): Bicknell Racing Products – Part Number: BRP 9547
Wehr's Machine & Racing Products – Part Number: WM397
Allstar Performance – Part Number: ALL4198
(no other manufacturer has submitted a design for approval at this time)

C1. Approved-Design Door Bar Clamp

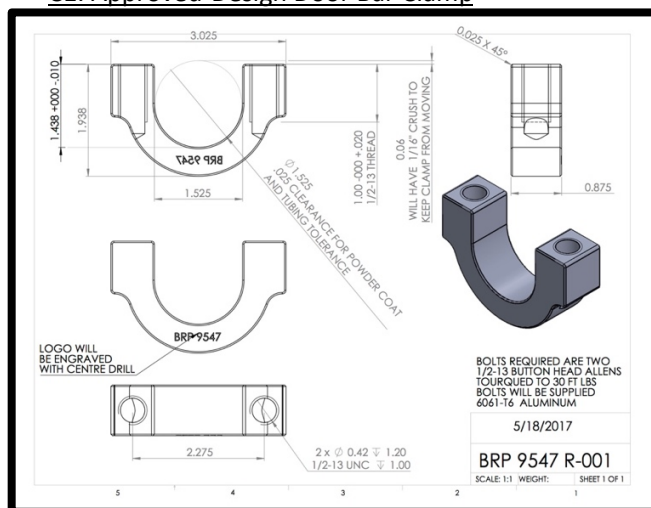

C2. Intrusion Plate with Approved-Design Door Bar Clamps

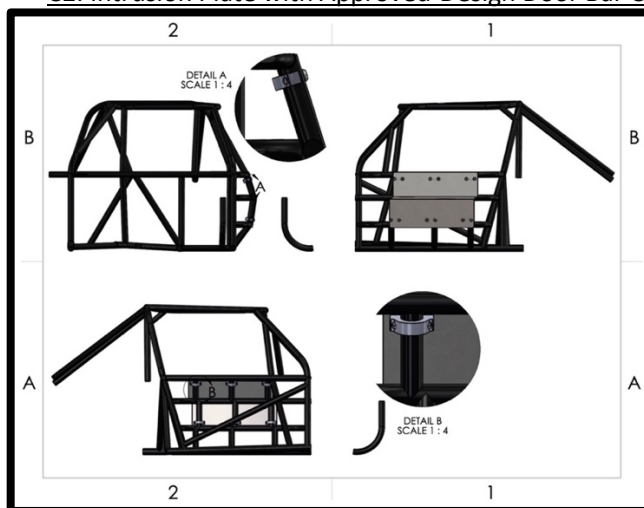

FIRE SUPPRESSION (mandatory for Dirt Late Models, DIRTcar Modifieds and Eldora Stocks)

- All racecars must be equipped with a thermally deployed automatic fire suppression system. The fire suppression system will consist of a DOT approved cylinder manufactured from aluminum or steel with a capacity of ten (10) lbs. of fire extinguishing agent, steel or steel reinforced lines, and a minimum of two (2) thermally activated discharge nozzles.
- All systems must meet or exceed SFI 17.1 specifications.
- Systems must be fully charged with ten (10) lbs. of DuPont FE-36, 3M NOVEC 1230, or Fire Aide and display a legible and valid SFI and manufacturer label depicting fire extinguishing agent, capacity, and certification date. Cylinders that are beyond useful certification date must be inspected, serviced and re-labeled by the manufacturer.
- Cylinders must be mounted forward of the fuel cell. Cylinders must be securely mounted to the frame/roll cage assembly. The certification label must be unobstructed and easily accessible for inspection when the mounting is complete.
- The cylinder must be connected to the nozzles with steel or steel reinforced lines.
- Two (2) thermally activated nozzles must be used. One (1) nozzle must be located directly above the fuel cell in the fuel cell area and the second nozzle located in the driver cockpit area. Additional nozzles are permitted.
- An optional manual override cable may be added to the system.

FUEL, FUEL CELLS AND FUEL SYSTEM (same as DIRTcar – includes Eldora Super Stocks)

- An approved fuel cell must be used at all times. Fuel cells must meet and/or exceed the FIA/FT3 or SFI 28.3 specifications or be constructed to these specifications. Key components of an approved fuel cell are: a metal container (.060 aluminum or 20-gauge steel), bladder, foam baffling for slosh and explosion suppression, top-mounted bolted fuel valve plate, flop valve and rollover vent valve, and threaded cap (ATL Part #751 Twist Cap approved for competition).
- Fuel cells must be used in accordance with the manufacturer's specifications. Alterations of any kind will not be permitted (example: alterations to top plate, alterations or removal of foam, etc.).
- Bolted fuel valve plate, fuel pickup and fuel return fittings must be on the top of the fuel cell.
- Fuel cells that are not contained within a welded steel tubing "rack" must have two (2) equally spaced steel straps that measure two (2) inches wide by 1/8 inch in thickness that completely surround the fuel cell. The straps must be bolted to the frame. Longitudinal (front to rear) orientation is recommended for strap mounting.
- Fuel caps must have car number. Willy's Carburetor roll over plate, #WCD4000, is approved for competition.

SAFETY EQUIPMENT (same as DIRTcar)

- Minimum SFI 16.5 or 16.1 approved racing safety harness is required. Restraints must be mounted per the manufacturer's instructions. The competitor is solely responsible for checking belts, equipment and harnesses for wear compared to the SFI date of expiration.
- Drivers, at all times they are on the track, must have their helmets correctly (following manufacturers installation and use instructions) connected to an approved head and neck restraint. Full-face helmets required. Driver's helmets must display a legible and valid FIA 8860-2010, Snell SA 2005, Snell SA 2010, Snell SAH 2010 and/or a valid SFI 31.1/2005 label. It is strongly recommended that helmets should have the Eject™ helmet removal system installed as per the manufacturer's instructions. The head and neck restraint must be SFI 38.1 approved and display a legible and valid SFI 38.1 label.
- The Original Equipment Manufacturers (OEM) of racing helmets recommend that helmets delivered with OEM bolt-on integrated aerodynamic features (aero devices, duckbills, gurney lips, wings, etc.) – especially those which are painted and/or wrapped by a graphics customizer – always be reassembled with OEM nylon bolts. OEM bolt-on accessories, as delivered from the helmet manufacturer, should not be re-affixed, bonded, glued or wrapped to the helmet by any method other than as delivered/recommended by the manufacturer as this invalidates the helmet's FIA, SFI or Snell rating. OEM-approved accessory pieces, including aero devices and forced air intakes, should always be attached with double-sided adhesive per the manufacturer's specifications.
- Drivers must wear a fire-resistant racing suit at all times they are on the track, during practice and competition. Driver's suit must meet or exceed SFI 3.2A/5 specifications and have a legible and valid SFI label.
- Drivers must wear gloves at all times they are on track, during practice and competition. Driver's gloves must meet or exceed the SFI 3.3 specification and have a legible and valid SFI 3.3 label.
- Drivers must wear fire resistant shoes at all times they are on the track, during practice and competition. Driver's shoes must meet or exceed SFI 3.3 specifications and have a legible and valid SFI label.
- A Racing Electronics SWITCH-R or RACEceiver is mandatory (no other scanning/transmitting device permitted).

SAFETY EQUIPMENT – RACECAR INSTALLED (same as DIRTcar)

- All seats must be "Full Containment" style constructed of aluminum to the general design specifications of current industry standards. Design shall include comprehensive head surround, shoulder and torso support system, energy impact foam, and removable head foam. Consult with your seat manufacturer and safety equipment manufacturer for questions and recommendations regarding upgrading your seat safety system.
- Seats manufactured using carbon fiber or composite materials must meet SFI 39.2 specifications.
- Up-fitting a current seat with bolt-on kits will be permitted with a seat manufacturer-produced kit and an acceptable base seat approved by the seat manufacturer. Consult with your seat manufacturer for recommendations regarding your current seat. Components must include comprehensive torso, shoulder and head surround support system with energy-absorbing impact foam. Must be installed in accordance to seat manufacturer instructions. Combining components may not meet SFI certification.
- Seats must be used as supplied and installed following instructions provided by the seat manufacturer. An exception of trimming the length of the left side head surround for the purpose of egress may be approved. If the left side head surround is trimmed to a distance that is less than seven (7) inches, then a left side head net meeting the SFI 37.1 specifications must be installed with a quick release latch, approved nets include the Simpson C5R: <http://simpsonraceproducts.com/harnesses/c5r-driver-net/>
- Seats must be mounted to a seat frame that is welded to the racecar frame/roll cage structure. Attachment points, angles, and materials for the seat frame and mounting of the seat to the seat frame must be in accordance to the seat manufacturer instructions.

The use of a SFI 39.2 certified seat is recommended

TIRES & WHEELS (same as DIRTcar)

- LATE MODELS: Hoosier LM 20 required on LF, RF and LR positions. Hoosier LM 20 or LM 40 option on RR. Alteration of the factory compound as manufactured via any means is prohibited.
- Approved wheel discs will be permitted on both sides of the car. Approved discs are those fastened to using a minimum of three (3) magnetic steel hex head bolts (min. size 1/4") or five magnetic steel dzus fasteners. Any other type of fastener will not be permitted. Wheel discs must be marked with the car number.

VIDEO RECORDING DEVICES

- Video recording devices (“Cameras”), examples include GoPro, Garmin, Replay, WASPcam, and similar, may not be mounted on the driver’s helmet.
- All cameras must be mounted to the chassis or roll bar with a mounting device constructed solely of metal and designed for auto racing. The camera and mount must be tethered.
- Lost cameras will not be returned.
- Eldora Speedway, Inc., owns the rights to all images, sounds and data from its events. Participants in events at Eldora Speedway agree not to take any action, or cause others to take any action, which would infringe upon Eldora’s rights. Admission to the venue constitutes acceptance of these terms. Live streaming is prohibited. Digital and video recaps posted to social media – including but not limited to using an on-car camera, multiple on-car cameras, personal cameras, and/or shots of the broadcast of the events – may violate an agreement between Eldora Speedway, Inc., and the exclusive licensee.
- For more information, contact Eldora Speedway, 13929 State Route 118, New Weston, Ohio 45348.