



---

# 2023 Eldora Million Rule Book

Date of Publication: May 8, 2023

Jerry Gappens – Promoter  
jerry@eldoraspeedway.com  
937-338-6009

# Table of Contents

<b>A) Preface</b> .....	3
1. Definition of Terms .....	3
2. Eldora Speedway Rules .....	4
<b>B) Membership</b> .....	5
1. Membership Eligibility .....	5
2. Conduct .....	5
<b>C) Personal Safety Equipment</b> .....	6
1. General .....	6
2. Seat Belt / Restraint System .....	6
3. Protective Clothing .....	6
4. Seats .....	6
5. Helmets .....	7
6. Other (HIGHLY RECOMMENDED) .....	7
<b>D) Racing Event Procedures</b> .....	9
1. Inspections .....	9
2. Pill Draw .....	9
3. Team Meeting .....	9
4. Hot Laps .....	10
5. Qualifying .....	10
6. Racing .....	11
7. Flag Rules / Official's Signals .....	15
8. Back Up Cars .....	16
<b>E) Scoring</b> .....	18
<b>F) Payoff Procedures</b> .....	19
<b>G) Alternate Starting Positions</b> .....	20
<b>H) Penalties, Fine Schedules &amp; Protests</b> .....	21
1. Penalties and Fine Schedules .....	21
2. Protests .....	22
<b>I) Car Rules</b> .....	24
1. Engines .....	24
2. Fuel .....	25
3. Muffler and Sound Reduction Devices .....	25
4. Traction Control Devices .....	26
5. Chassis/Frame .....	26
6. Weight .....	30
7. Body .....	30
8. Wings .....	32
9. Wheels / Wheel Covers .....	35
10. Tires .....	36
11. Shocks .....	38
12. Other .....	38

## **A) Preface**

The Eldora Million event which is intended to be conducted and officiated in accordance with the rules herein (the 2023 Eldora Million Rule Book). The rulebook may be amended from time-to-time and special rules may be published and/or adjusted at any particular event with the participants receiving prior notification. By participating in these events, all participants agree to comply with these rules and regulations.

The rules are not intended to express or imply the warranty of safety as a result of publication of, or compliance with the rules and regulations as stated herein. The rules are intended to offer a guideline for the conduct and officiating of an event.

The Eldora Million shall be empowered to permit any reasonable and/or appropriate amendment from any of the specifications and/or procedures herein, or impose any further restriction that, in their opinion, does not alter minimum acceptable requirements. Revisions to the rules are not intended to express or imply the warranty of safety as a result from any such deviation or restriction of the specifications, rules and/or procedures. Any interpretation of, deviation from, these rules herein, is left to the discretion of the racing officials and their jurisdiction is final.

Eldora Speedway reserves the right to immediately determine the legality and use of any equipment that has not received prior written approval for introduction into competition.

It is ultimately the obligation of each participant to ensure their conduct and equipment comply with all of the applicable rules, as they may be amended from time-to-time. The rules are in no way a guarantee against injury and/or death to participants, spectators, officials and/or others.

### **1. Definition of Terms**

**The following terms, which appear periodically throughout this Rule Book, have the following meanings:**

- a) **“Eldora Million”** – The trade name for the events.
- b) **“Eldora Million Rule Book”** – The rules in this Rule Book, as they may be amended from time-to-time.
- c) **“Eldora Officials”** – Persons employed or contracted by Eldora Speedway to officiate at an event, sometimes referred as “Officials.”
- d) **“Event(s)”** – The Eldora Million events.
- e) **“Promoter”** – The individual, partnership, corporation, joint venture and/or other legal entity that, in connection with the Event, is designated as the “Promoter” in the executed Sanction Agreement for the Event.
- f) **“Competitor”** – A driver, car owner, crew member and/or any other person (other than an Eldora Official) who participates competitively in the Event. Whenever the words Competitor, driver, car owner, mechanic, team member and/or crew member are used, unless the context indicates otherwise, the term used shall be interpreted to include any driver, car owner, crew member and/or other person assigned to or a member of the same racing team.
- g) **“OEM”** – Original Equipment Manufacturer.
- h) **“Split Scoring”** – In the instance that there is a caution after the leader and at least one other car has crossed the scoring loop, split scoring will be used. The lap that the leader and a least (1) other car had crossed the

scoring loop will be counted as an official lap of the race: those cars that crossed the scoring loop before the caution will be scored in the manner in which they crossed the scoring loop. Those cars that had not yet crossed the scoring loop at the time of the caution will be scored in their position in which they crossed the scoring loop on the previous lap. On all laps, except the final lap, at least 2 cars must cross the scoring loop to qualify for split scoring. On the final lap, only the leader must cross the scoring loop for split scoring to be utilized.

- i) **“Sprint Car”** – A specified racing vehicle that fits the specifications set forth in this Rule Book.

## **2. Eldora Million Rules:**

- a) **Effective Date** – The rules within this book are effective upon the date of publication by Eldora Speedway for the Event, regardless of when a Competitor receives the actual notice. “Date of Publication” of the rules or any amendments thereto is the earliest of distribution from Eldora Speedway and/or release to the press.
- b) **Amendment** – The Eldora Million rules may only be amended by publication of an amendment in an issued release pursuant to the authority of Eldora Speedway. An amendment is effective upon the date of the publication, regardless of when a Competitor receives the actual notice.
- c) **Interpretation and Application** – If there is a disagreement or dispute regarding the meaning or application of the rules, the interpretation and application of the Eldora Officials at the Event will prevail.
- d) **Finality of Interpretation and Application** – The interpretation and application of the Eldora Officials at the event shall be final and non-appealable. ALL COMPETITORS AND OFFICIALS, EXPRESSLY AGREE THAT DETERMINATIONS BY ELDORA OFFICIALS AS TO THE APPLICATION AND INTERPRETATION OF THE RULES ARE NON LITIGABLE, AND THEY COVENANT THAT THEY WILL NOT INITIATE OR MAINTAIN LITIGATION OF ANY KIND AGAINST ELDORA SPEEDWAY, INC. OR ANYONE ACTING ON BEHALF OF THE ELDORA SPEEDWAY, INC, TO REVERSE OR MODIFY SUCH DETERMINATIONS OR TO RECOVER DAMAGES OR TO SEEK ANY OTHER KIND OF RELIEF AS A RESULT OF SUCH DETERMINATIONS, UNLESS THE OFFICIALS MADE SUCH DETERMINATIONS FOR NO PURPOSE OTHER THAN A BAD FAITH INTENT TO HARM OR CAUSE ECONOMIC LOSS TO THECOMPETITOR OR OFFICIAL. IF THE COMPETITOR OR OFFICIAL INITIATES OR MAINTAINS LITIGATION IN VIOLATION OF THE COVENANT, THAT COMPETITOR OR OFFICIAL AGREES TO REIMBURSE THE ELDORA SPEEDWAY FOR THE COSTS OF SUCH LITIGATION, INCLUDING ATTORNEY’S FEES. EACH COMPETITOR OR OFFICIAL FURTHER COVENANTS THAT IN ANY LITIGATION BROUGHT AGAINST ELDORA SPEEDWAY FOR ANY REASON, IF THE LITIGATION IS NOT DISMISSED PURSUANT TO THIS COVENANT THE MATTER WILL BE TRIED BEFORE A JUDGE OF COMPETENT JURISDICTION AND HEREBY WAVES ANY RIGHT TO TRIAL BY JURY IN SUCH ACTION.
- e) **Principal Rule of Interpretation and Application** – The rules are intended to ensure that Events are conducted in a manner that is as fair as possible for all competitors, consistent with prompt finality in competition results. On occasion, circumstances will be presented that are either unforeseen and/or otherwise extraordinary, in which strict application of the Eldora Million rules may not achieve this goal. In such rare circumstances, the Eldora Officials, as a practical matter, may make a determination regarding the conduct of an event, the eligibility of a Competitor or similar matters that are not contemplated by or are inconsistent with the Eldora Million rules, in order to achieve this goal. From time-to-time in particular rules, Official Entry Blanks, Bulletins and elsewhere, Eldora Million may use the term “EIRI” meaning “Except in Rare Instances” to indicate the likelihood that such a determination may be made.
- f) **Special Rules** – Special rules may be made by the Eldora Officials for an event. Such special rules shall apply to the conduct of the event if they are published or announced prior to or during the event by means of bulletin, email, headset, newsletter, telephone, and/or pre-race Team Meeting.

## **B) Membership**

### **1. Eligibility**

#### **a) Minimum Requirements**

- i. To be approved, secure and maintain an Eldora Speedway Membership at minimum must:
  - a. Be at least 16 years of age
  - b. Ages 16 and 17:
    - i. A parent must sign the Release and Indemnity Agreement.
    - ii. Execute and deliver to Eldora Speedway such authorizations, releases, applications, consents, waivers, resumes and other documents as maybe required from time-to-time.
- ii. Following completion of all documentation, waivers, consents, resumes, other documents and/or training modules, a driver must be approved by an Eldora Officials for competition before becoming eligible to participate in the Events.

### **2. Conduct**

#### **a) General**

- i. All competitors agree to act in a professional manner as determined by Eldora Million Officials. The professional manner includes, but is not limited to verbal representation, written representation, electronic representation, social media and/or any representation that may represent the Eldora Million, Eldora Speedway, the sport of Sprint Car racing and/or motorsports in general and/or any affiliates.
- ii. All competitors will not be permitted to compete and/or participate while under the influence of any alcoholic beverages and/or illegal substances.
- iii. During the Event, any Competitor may be requested to report to an Eldora Million Official. The request may be communicated over the one-way radio and/or verbally. Failure to comply with the request will be subject to fine and/or suspension and/or any other action deemed appropriate by Eldora Million Officials.
- iv. As a disciplinary action, a driver and/or race team may be parked during and/or after any Eldora Million event. Parking is a directive from an Eldora Speedway Official to cease competition and may include a directive for the competitor(s) to not participate in an event for a set number of laps and/or complete event(s) and/or future events and/or leave the premises in order to promote the orderly conduct of the Eldora Million. This directive will only be given in extraordinary circumstances by the Eldora Speedway Official. Parking will not be construed and/or deemed to be a disqualification and/or suspension and/or other “penalty” as referenced in Section I and is not appealable.

## **C) Personal Safety Equipment**

### **1. General**

- a) Each Competitor is solely responsible for the effectiveness and proper installation, per the manufacturer's specifications, of personal safety equipment and determining it to be acceptable for competition at every event. Each Competitor is expected to investigate and educate themselves for continuing improvement regarding their own personal safety equipment.

### **2. Seat Belt/Restraint System**

- a) Each car will be equipped with minimum of an SFI 16.1 or SFI 16.5 approved restraint system, until the date of the belt expiration (two years from the date of manufacture). Seat belt restraint systems shall be installed and used in accordance with manufacturer's instructions. In any type of manufacturer's installation, the fasteners must be as supplied by the manufacturer. No belts to seat installation will be allowed. Belts must bolt to or wrap around the chassis. A seven- point harness is recommended.
- b) Seat belt material should not be permitted to come in contact with any sharp or metal edge, including when the material passes through the seat.

### **3. Protective Clothing**

- a) All drivers will be required to wear a fire resistant driving uniform meeting minimum SFI 3.2A/5 specifications and display a valid SFI 3.2A/5 label.
- b) All drivers should wear fire resistant accessories, including, but not limited to: head sock, under garments, shoes and socks. All drivers will be required to wear fire resistant gloves. Shoes and gloves will be required to meet minimum SFI 3.3 specifications and display a valid SFI 3.3 label.

### **4. Seats**

- a) All current aluminum seats must be full containment type construction and must adhere to the general design specifications of SFI 39.2 seat construction standards. Design shall include comprehensive head surround, shoulder and torso support system, energy impact foam, and removable head foam.
- b) Approved carbon fiber seats must have a current valid SFI 39.2 Certification.
- c) Up fitting a current seat with bolt on kits will be permitted with a seat manufacturer produced kit and an acceptable base seat approved by the seat manufacturer. Components must include comprehensive head surround, shoulder and torso support system, and energy impact foam. It must be installed in accordance to seat manufacturer instructions. Combining components may not meet SFI 39.2 Certification.
- d) Seats must be used as supplied and installed following instructions provided by the seat manufacturer.
- e) If the left side head surround is 7 inches or less when measured from the back of the headrest, then a left side head net meeting the SFI 37.1 must be installed with a quick release latch. A minimum left side head surround of 4 inches is required.
- f) The recommended driver's seats may be revised from time-to-time with additional approvals and/or other changes to the approved list.

- g) A right side head restraint net and/or support are required. All head restraint nets should be equipped with quick release mechanisms.
- h) The approved nets may be revised from time-to-time with additional approvals and/or other changes to the approved list.

## **5. Helmets**

- a) All drivers will be required to wear a full-face helmet with a minimum safety rating of FIA 8859-2015, FIA 8860-2018, Snell SA2020, Snell EA2016, or Snell SA2015.
- b) It is strongly recommended that helmets have the Eject™ helmet removal system installed as per the manufacturer's instructions.
- c) At all times during an event including practice, qualifying and competition (excluding starting the car for engine warm-up) it is required that drivers wear an SFI-approved head and neck restraint device/system that is properly mounted and connected per the manufacturer's instructions. The device should meet SFI 38.1 specifications and display a valid SFI 38.1 label.
- d) Arm restraints are recommended and must be connected and used as instructed by the manufacturer.

## **6. Other (HIGHLY RECOMMENDED)**

- a) No sharp and/or protruding edges in and around the cockpit.
- b) Windshield screens should be a minimum thickness of 0.090 inch and should be securely fastened to the roll cage.
- c) A clearly marked electrical engine shut off switch within reach of the driver.
- d) A clearly marked fuel shut off valve within reach of the driver.
- e) Only SFI flame retardant seat, roll bar, knee and steering pads and/or padding should be utilized.
- f) A drive line containment system; either a steel torque ball housing made of a minimum .120 wall thickness magnetic steel attached to the firewall with steel and/or titanium bolts and/or a torque ball u-joint containment blanket is highly recommended to shield revolving parts within the cockpit.
- g) All teams should have an easily accessible 2.5 gallon FFF fire extinguisher or its equivalent at the back of the team's transporter.
- h) Fire Suppression systems are highly recommended for 2023. If a fire suppression system is installed, it must be installed securely and meet or exceed SFI 17.3 specifications and must meet the following:
  - i. System must include a thermal trigger and a manual trigger, both mounted in the driver's compartment. The thermal trigger must be in the lower area of the drivers compartment forward of the seat near the area of the fuel pump. The manual trigger must be mounted within reach of the driver on the forward left-hand side of the cockpit. A minimum of one nozzle must be mounted in the lower area of the cockpit forward of the seat.
  - ii. A DOT approved cylinder manufactured of aluminum or steel must be securely mounted to the frame per the manufacturer's instructions and the discretion of the Eldora Officials. The cylinder must have a minimum capacity of 5 lbs.

- iii. The system must be fully charged and display a legible and valid SFI 17.3 and manufactures label, easily viewable at any time by Eldora Million Officials. Cylinder that are beyond useful certification date must be inspected, serviced, and re-labeled by the manufactured.
- iv. If a nozzle is connected to the cylinder with a line, the line must be steel or steel reinforced and must be triggered at the end of the line.
- v. Approved Manufactures are:
  - Lifeline Fire & Safety USA, (540-251-2724)
  - Safety Systems Inc. (Firebottle), Ft Myers, FL (239-995-6300)
  - Spa Technique Inc., Indianapolis, IN (317-271-7941)
  - Safecraft Safety Equipment, Martinez, CA (800-400-2259)



## **D) Racing Event Procedures**

The rules as stated herein will cover the procedures and rules of the racing event. Procedures and rules of the racing event may be altered from time-to-time by Eldora Officials. Racing event procedures and/or racing event rules are final and non-appealable.

### **1. Inspections**

- a) All cars entered and present that are intending to compete in the racing event must pass pre-race inspection prior to any on-track activity and must have or obtain a current inspection decal and affixed to the chassis. Pre-race inspection may take place in a specified area and/or in the regards of space directly at the team's transporter. Refusal to present vehicle or preventing Officials from completing pre-race inspection will result in disqualification from that event in addition to potential penalties, suspension and/or fines.
- b) All cars are subject to a complete inspection at any time during the event.
- c) Fuel will be inspected during periodic intervals utilizing a hydrometer and by chemical analysis through a fuel chemist. If a fuel sample is chemically analyzed, all winnings of that particular car from that particular racing event will be held until the analysis has been completed and a determination has been made by Eldora Million Officials.
- d) Eldora Million Officials may at their discretion, inspect any car entered for competition in any Event at any time.
- e) Eldora Million Officials may at their discretion, impound a part/component, engine and/or any other components and/or the complete car for competitive analysis and/or research data.

### **2. Pill Draw**

- a) All drivers and teams must draw for a position in time trial qualifying in order to be officially entered for the event. The pill draw take place inside the Eldora Media Center. Drivers and/or teams are responsible for their own pill draw.
- b) All pills must be drawn prior to the posted Team Meeting time. Teams will have the ability to have someone draw for a time trial position on their behalf if the team is late arriving.
- c) If a car and driver show up after the start of the Team Meeting, but before qualifying has ended, they will be placed at the end of qualifying and be given one lap to qualify with a time no better than one spot out of the heat race inversion. They will however, be placed into the corresponding group that would be the next group to have a car added to it in the chronological order.
- d) If any car(s) scratches after the pill draw and before the start of the Team Meeting, they will be removed from the entry list.
- e) The entry list becomes official at the start of the Team Meeting.

### **3. Team Meeting**

- a) All drivers along with one crew member from each competing team must attend the Team Meeting. Those teams in violation of not attending the Team Meeting could face a loss of Every Lap Matters Points.

- b) The number of racecars starting each event and the number of laps for each event is detailed in the official Eldora Million entry form. Any changes will be announced at the Team Meeting.
- c) Eldora Speedway, Inc. reserves the right to alter show format and revise race procedures due, but not limited, to: car count; inclement weather; challenging track conditions; and/or other extenuating circumstances.

#### 4. Hot Laps

- a) If wheel packing is necessary, participation is required to retain time trial position. If a car and driver do not wheel pack, they will be placed at the end of qualifying and be given one lap to qualify with a time no better than one spot out of the heat race inversion.
- b) Drivers must hot lap in listed group unless having trouble that is reported to an Eldora Million Official.
- c) Except in rare instance hot laps will be limited to one session per group.

#### 5. Qualifying

- a) Qualifying will consist of two consecutive timed laps and 2 cars at a time. Changes to the two-lap qualifying procedure will be at the discretion of the Eldora Million Officials.
- b) Free laps during time trials will not be given. When a car is pushed for time trials it must make its attempt beginning at the same time all other cars are making said attempt. Also, during time trials all cars must begin accelerating at the same point on the surface, meaning if a car's attempt is yellow flagged or slowed for any reason or halted due to a red flag condition, once cleared to resume the attempt, the throttle must be picked up in the same location as all other cars. If a driver feels he was interfered with during his qualifying attempt, he must notify the Eldora Million Officials at the scale area, and if another attempt is granted, report directly back to the time trial push off area to be the next available car to qualify and be given one additional lap. Once the car leaves the scale area no interference lap will be granted.
- c) Qualifying will take place in the order of the pill draw. Each car and/or team will have a two-car grace period to be in line for their own qualifying opportunity. If the grace period is missed the late car will take its time trial at the end of overall qualifying and receive only one qualifying lap and the best a late car can qualify is the first car outside the invert, notwithstanding the actual qualifying time of record as posted. Once a car is pushed for qualifying, even if it doesn't start, it is considered an attempt to qualify. If the car leaves the track and goes to the pit area or returns to the qualifying push lane, it will be considered late and will only receive one qualifying lap at the end of overall qualifying and the best it can qualify is the first car outside the invert.
- d) The cars and/or teams that are late must be in line before the last scheduled car pushes off. Qualifying will be closed once all cars that are in line have been pushed off to begin their time trial.
- e) In the event of two or more cars posting the same time in time trials, the tie breaker will be the fastest other lap time of the two consecutive recorded laps. If this does not break the tie, the tie will be broken by the qualifying order draw. In the event that one (1) lap qualifying is utilized, the tiebreaker will be the qualifying order draw. The car that with the lowest pill draw will be awarded the faster time.
- f) Any car that fails post qualifying inspection (i.e. fails to report directly to the scales, too light at scales, illegal tire, wings, wheels, etc.) will lose its qualifying time of record and receive zero Every Lap Matters points, but will be lined up as the last car in their respective heat race.
- g) All cars must report directly to the scale location after completing their time trial lap(s) and meet the minimum required weight with the driver in the car. If time trials are interrupted due to weather or an electronic timing issue any hot lap/ heat race groups that have been completed will retain those times. Whichever group(s) had

the interruption will need to re-qualify once the weather allows or electronic issue has been fixed or timing light is set up.

## 6. Racing

### a) Starts

- i. Any driver, team, and/or car, who purposely attempts to hold up the start of any race will be placed at the rear of the lineup and could be disqualified from the event at the discretion of the Eldora Million Officials.
- ii. Once the allotted time (announced at the Team Meeting) allowed for being on the track or in the push off lane ready to race has expired, any late arriving car will be penalized two (2) starting positions. Any car pushed after the field has started assembling must start at the rear of the field. This rule may be adjusted from time-to-time, "EIRP", at the discretion of the Eldora Million Race Director.
- iii. All starts will take place at a consistent speed. Consistent speed will be at the discretion of Eldora Million Officials. Starts will take place within a designated area that will be identified at the Team Meeting. The pole setter is to set the pace for the field. The two (2) front row cars must choose their racing line entering turn three (3) and must maintain that line until the start or restart occurs. Failure to do so will result in a two (2) position penalty. The two (2) front row cars will begin the race by firing together at the chalk line in the area of turns 3 & 4. Any car out of line and/or passing before the front row has fired will bring out a caution period and will be penalized two (2) positions on the ensuing restart. However, if the offending car(s) was located in the second half of the starting grid, the race may be allowed to continue and the offending car(s) will be penalized two (2) positions from their finishing position. If the same car(s) commits a second offense it shall be disqualified from that racing event.
- iv. In the event that the race is not properly started by the two (2) front row cars, the responsible car or cars will be moved to the second row. Failure to acknowledge and comply with the "move back" signal will result in instant disqualification from the racing event.
- v. Alternates are allowed for A-Feature events only. Alternate starters will not be permitted to start any race after the original start has taken place. Alternates can enter the race up until the yellow lights go out. If the yellow or red lights comes on for any reason i.e. (debris, lineup incorrect or other reasons) before the initial green flag is taken the Alternates may still enter the A-Feature. Only original qualified cars (NOT Alternates) will be allowed to enter the race after the initial green, assuming 1) there are no laps completed AND 2) an alternate has not taken the original start.
- vi. After 3 unsuccessful attempts at a double file start or restart, Eldora Million Officials have the option to start the race in a single file formation.

### b) Restarts

- i. All restarts will take place with the lead lap cars moved to the front of the field. Lapped cars will pull to the inside and fall in behind the last car on the lead lap in their order of running.
- ii. All races will restart double-file in their entirety and utilize the "Choose Cone". Under yellow-flag conditions, the field initially goes to a single-file grid. Once the running order has been established and the field is set, the leader will be shown the "Choose Cone" which will be located on the frontstretch. Drivers must choose the inside or outside lane before they pass the cone on the front straightaway. Drivers must maintain their chosen inside or outside position until the full field order is established. Drivers must follow the tire track of the car in front of them.

- iii. No flare outs until the front row fires. Any car out of line and/or passing before the front row has fired will bring out a caution period and will be penalized two (2) positions on the ensuing restart. However, if the offending car(s) was located in the second half of the starting grid, the race may be allowed to continue and the offending car(s) will be penalized two (2) positions from their finishing position. If the same car(s) commits a second offense it shall be disqualified from that racing event. The Start/Restart Zone and procedures will be further detailed and reviewed at the Team Meeting.
- iv. The leader must fire first within the restart zone. If the leader is unable to properly restart the race after one (1) attempt, the leader may be warned or penalized two (2) positions.

c) E, D, C, B-Features

- i. The Non-Qualifier, E, D, C, or B-Features will be cancelled if one or multiple cars scratch and the number of starters will all transfer to the ensuing Feature. Such cars will tag the back of the next race by their previous lineup order.

d) A-Feature

- i. Unless instructed to do otherwise, the top three (3) finishers from the A-Feature must proceed directly to the scales to be weighed. Upon clearing the scales drivers must proceed directly to victory lane and participate in all victory lane activities, including, but not limited to, top 3 photos, victory lane photos, Media Center interviews, etc. Failure to report to the scales will result in a disqualification. Failure to report to victory lane could result in a fine and/or probation. Any extenuating circumstances will be considered.

e) General Racing Procedures

- i. Competitors may stop on the track during any yellow flag situation to alert an official of an unsafe condition including but not limited to driver radio not working, debris on track, incorrect line-up, driver's safety equipment malfunction, etc.
- ii. Any car that does not race on the designated racing surface in order to better its position may be black flagged and penalized at the discretion of the Eldora Million Officials.
- iii. Cars will not be permitted to be 'pushed-off' after the lights out signal has been given or during any green flag conditions. An offending car will be automatically disqualified.
- iv. A caution flag may be thrown for any car(s) that does a 360-degree spin during green flag racing. At the discretion of the Eldora Million Officials, 1) a caution flag can be immediately called if the car(s) spin poses an impact to other drivers or 2) not call for a caution flag if the spin occurs to a car(s) running near the end of the field and poses no impact to other drivers. Car(s) that perform a 360-degree spin and can continue without stopping after a caution has been called, even if contact is made with another car or obstruction, will not be charged with a caution.
- v. If the flagman throws the caution flag without direction from the Eldora Million Officials and the Official deems the caution to be not necessary, all cars will retain their position from the last lap in which they were scored.
- vi. If the flagman throws any flag without direction from the Eldora Million Officials and the Official deems the flag to be thrown in error, the caution flag may be thrown and Eldora Million Officials will communicate to drivers via one way radio communication. All running cars will retain their position from the last lap in which they were scored prior to the erroneous flag being thrown and the race will be continue from the last lap scored.

- vii. At the discretion of the Eldora Million Official, any car that is involved in two (2) single car spins that are unaided may be disqualified from the event.
- viii. At the discretion of the Eldora Million Official any car that intentionally brings out a caution period will be disqualified from the event.
- ix. Any car that cannot maintain a minimum race speed may be asked to leave the racing surface at the discretion of the Eldora Million Officials.
- x. All races must be completed in a 'green-white-checker' finish. If the race is slowed or stopped on the WHITE FLAG lap prior to the leader receiving the checkered flag, that race will be restarted and run for two consecutive laps before Completion.
- xi. If a race is red flagged and cars are sent to the pits, then any and all work, including tire changes, are permitted, except for the right rear tire during heat races or the A-Main.
- xii. Any cars that require a push start during a yellow caution period, will be considered involved in the incident which brought out the yellow flag and that car will have to restart behind the cars on the same lap that stay on the track.
- xiii. Any cars that stop, either on the racing surface and/or in the pit/designated work area or leaves the track unauthorized during a caution period will be required to restart behind the cars on the same lap that stay on the track.
- xiv. Any car or cars that are involved in a yellow or red flag situation including non-involved cars that go to the work area are required to restart behind cars on the same lap that stay on the track.
- xv. If a yellow flag eventually results in a closed red flag situation and the determination is made to go to an open red then all cars that were considered involved in the initial accident whether they went to the work area or not will re-align at the rear of the field in their scored position on their last completed lap. Order is lead lap cars, 1 lap down cars, and multiple lap down cars.
- xvi. Any car that spins-out as the field is stopping for a red flag situation will retain their running position as long as such car does not go to the designated work area.
- xvii. A spin or stoppage that requires a car to be restarted during a yellow flag slowdown period is considered as being involved and will result in that car or cars restarting behind the cars on the same lap that stay on the track.
- xviii. Any car that stops because of a blocked track, at the discretion of an Eldora Million Official, will not be considered involved in the red or yellow flag incident.
- xix. Any car that is stopped for consultation during a caution period will retain its position only if the Eldora Million Officials deem the car 'clear' and permit it to return directly to competition without adjustment.
- xx. Any car that requires a push-off at any time during an event must have a rear bumper in place.
- xxi. If it is determined in any race, after the original start, that any competitor deliberately initiates a caution period, by any means, that competitor will not be permitted to restart that race. The determination of what constitutes deliberately instituting a caution period will be at the judgment of the Eldora Million Officials.

- xxii. Adding fuel, whether on the track or in the work area, will not be permitted when yellow flag and/or closed red flag conditions exist. Violators are subject to disqualification and/or fine and/or suspension and/or any other action deemed appropriate by Eldora Million Officials
- xxiii. In the event that a race car is inadvertently or purposely hit by a push truck, pace vehicle, or another race car during push-off, or under yellow flag conditions or other non-racing activity and such incident is witnessed by an Eldora Million Official, then repairs can be made to the contacted vehicle and that car will maintain its running position. The maximum time period allotted for such repairs is six (6) minutes. If repairs can be completed within this time period then the car will be scored where it was running or scheduled to start when such accident took place. Alternate(s) starters will not be given a starting position in this situation. In the event that the car may not complete the race, the car will be scored last on the lap in which that car has completed.
- xxiv. For any cautions after the initial green flag has been displayed and without completing a lap, the line-up would be adjusted as follows: any cars not involved in the caution will be criss-crossed.
- xxv. Designated work area time is 2 minutes. Work area is always open; however, 2 minutes will not be given after push off (prior to green flag), and last half of all Main events (After the leader plus (1) car cross the scoring loop and receive the halfway signal). Work area trips are limited to one during preliminary events. No changing of any tire or wheel unless flat or damaged and approved by an Official. No adding fuel in the work area unless it's an open red. Any cars going to the work area and re-entering the race together will be positioned in the order of their last scored lap at the rear of the field behind cars that are on the same lap as they are. If a restart green flag is displayed and followed by a yellow or red flag before a lap is scored, then any car(s) that remained in the work area can re-enter the race but will be positioned behind any same lap car that took the aforementioned restart green flag. Any car(s) remaining in the work area after a restart lap has been scored, may NOT re-enter that race.
- xxvi. Late arriving driver and car combinations will be allowed to race under the following guidelines:
  - a. If car and driver arrive after time trials are completed, they will be placed at the tale of the heat race that is next to have a car added to it. Once the first heat is started, no cars can be added to heat races.
  - b. If car and driver arrive after the first heat race has started, they can be placed at the tail of either the E, D, C or B-Feature line-up. Cars will need to start those races in order to get paid.
  - c. If car or driver arrive after the first heat race has started and there is no B-Feature, car and driver would need to start the A-Main in order to get paid. If car and driver do not start the A-Feature, they will not be paid.
- xxvii. If any car which has been confirmed "scratched" to an Eldora Million Official by a designated team representative, wishes to re-enter, the car must start on the tail of any event it is qualified for. If any cars scratch or elect to go to tail prior to a race line-up being posted on the line-up board, remaining cars will be criss-crossed forward in the line-up.
- xxviii. All work on the racecar, once any race has been staged, must be completed in the designated work area unless informed otherwise. Any participants who work on the car other than in the designated work area are subject to disqualification and/or fine and/or suspension and/or any other action deemed appropriate by Eldora Million Officials.
- xxix. All cars will receive only one (1) 'push-off' per race. If a car needs more than one (1) 'push-off', except for safety reasons, during any race, that car will be placed at the tail end of cars on the same lap. A 'push off' is considered completed only when the pushed car has started and pulled away from the push vehicle.

- xxx. Competitors will not be permitted to tamper with track racing surface. Any participants who tamper with the track racing surface are subject to disqualification and/or fine and/or suspension and/or any other action deemed appropriate by Eldora Million Officials.
- xxxi. The addition of bolt-on weight during any yellow and/or red flag condition will not be permitted.
- xxxii. The Eldora Speedway scales will be available and open to scale cars prior to hot laps.
- xxxiii. All cars are subject to being weighed at any time during any event.
- xxxiv. If a car is found to be light after any race, it will be scored last for the event. Any car that is found to be light after the A-Main will be scored last, awarded last place points, and receive last place money. If a car is found to be light after any race that awards Every Lap Matters points, it will be awarded ZERO points for that race.
- xxxv. Eldora policy – ONE roll off and re-scale attempt only - EIRI
- xxxvi. When instructed to do so by the Eldora Million Officials, cars must proceed immediately to the scale area. Competitors will not be permitted in the area and/or to approach the car prior to reaching the designated area until it is weighed and released by an Eldora Million Official.
- xxxvii. Except for extenuating circumstances drivers must remain seated in their typical racing position in the vehicle during the weighing process unless released by Eldora Million Officials. If a driver leaves the car without prior consent it could result in a disqualification from the event in which the car is competing in.

## **7. Flag Rules/Official's Signals**

### **a) Green Flag:**

- i. When the starter displays the green flag, the track is open for racing.
- ii. The green flag signifies the start or restart of any race and/or time trial run.

### **b) Yellow Flag:**

- i. When the yellow flag is displayed and/or the yellow caution lights are illuminated, this signifies a caution period.
- ii. When the yellow flag is displayed and/or caution lights illuminated no passing is permitted unless instructed to do so by Eldora Million Officials.

### **c) Red Flag:**

- i. When the red flag is displayed all cars on the racing surface and in the pit areas must come to a complete stop in a controlled manner, while not stopping and/or driving through the area of the incident.
- ii. During any red flag situation all drivers, unless involved in the incident, must remain in their car unless otherwise instructed by Eldora Million Officials.
- iii. At the discretion of the Eldora Million Officials a work area may be designated on the racing surface. All cars will be pushed to the designated work area on the racing surface before work begins.

- iv. **CLOSED RED:** The track will be closed. Competitors will not be permitted on the race track and/or to their race cars.
  - v. **OPEN RED:** The Eldora Million Director will determine when the track is open. When the Eldora Million Director determines that the racing may resume; an air horn designating the start of a 2-minute work period will be sounded. Any repairs and/or adjustments, except changing a tire or wheel, can be made to the race car. At one minute remaining, the air horn will be sounded twice. At the end of the 2-minute period the horn will be sounded, officially ending the work period. Crews must be clear of their car when the 2-minute period has expired or be penalized 2 running positions. Last row cars violating this procedure will be penalized 2 positions from their finishing position. Any car still being worked on once the field has started assembling will be disqualified and not allowed to re-enter the race.
  - vi. **FUEL RED:** As soon as all the crews have reached their cars an air horn designating a 2 minute work period will be sounded. The 2 minute work period procedure is the same as outlined for an OPEN RED. Any repairs and adjustments, except changing a tire or wheel, can be made to the race car as long as they are completed before the 2 minute period has expired.
- d) **Black Flag:**
- i. When a black flag is displayed for the sprint car (mechanical, tire, wing, etc.), the driver that the flag is being displayed toward must bring their car to the designated work area immediately for consultation. The car will not be scored from the point that the black flag has been displayed. If after the car is inspected and it is able to return to competition, the car may only return to the track during a caution and/or red flag period.
  - ii. When a black flag is displayed for the detrimental actions of a driver, the driver that the flag is being displayed toward must bring their car to the pits and both the driver and car are subject to Event disqualification.
- e) **White Flag:**
- i. If the white flag is displayed and the leader of the race crosses the scoring loop, it signifies that the leader of the race and/or the car that is qualifying has started the last lap of that event.
- f) **Checkered Flag:**
- i. When the leader of the race crosses the finish line under green flag conditions on the final lap, it signifies the completion of the race and/or the car that is qualifying has completed qualifying. Split scoring will be utilized, per the definition above, if a caution is called after the leader has crossed the finish line on the final lap.
  - ii. Eldora officials will use any available data, including the transponder lap recording device, and undisputed photography and video evidence in the judgment of Eldora Timing and Scoring to determine the first car to break the plane of the finish line as designated on the inside and outside walls.
- g) **Officials Signals:**
- i. All drivers must obey signals, communications, and/or any other Official's communications that assist in the direction and facilitation of creating proper lineups and/or the process of completing the event.

## **8. Back Up Cars / Driver Changes**

- a) Any substitute driver must be a driver that has not already competed in the respective event. Once a driver has qualified his/her car that shall constitute competing in respective event.



- b) A backup car may be introduced at any time between qualifying and the start of the A-Main due to the original car not operating properly and/or from extensive damage. Such determination will be at the sole discretion of the Eldora Million Officials.
- c) Any such change will result in the driver starting at the rear of the next race in which the car has qualified for.
- d) If a driver changes cars after practice, that driver will remain in his drawn position for time trial qualifying and will be positioned in subsequent races accordingly. If a backup car is introduced, the car must pass pre-race technical inspection prior to any competition. A backup car may be obtained from any source and does not have to be part of a team's original equipment. Once a car has been withdrawn by a team from an event, that car will not be allowed to be resubmitted to competition during that event.
- e) If a car is entered into an event, it may only be used as a backup for another team if the car has completed its racing events without successfully qualifying for the next respective race. For example, if a car did not transfer to the B-Main thru the C-Main, that car would then be eligible to be used as a backup car for another team. If a team voluntarily withdraws its car from an event without completing the racing events in which the car qualified for, that car is not eligible to be used as a backup for another team.
- f) **If a portion of the event is re-scheduled for another date, the car owner retains the starting spot.**

## **E) Scoring**

- a) Split Scoring will be utilized for all races within the Event.
- b) All races are scored at the designated finish line. Electronic scoring loop may not always be the same location as the finish line.
- c) The official starting lineup will be posted by the Eldora Million Officials after the completion of all qualifying events.
- d) Restart lineups will be derived from the Series scorer using the electronic scoring system.
- e) All cars that were scored under green flag conditions will hold that scored position with all other cars lining up according to their last completed green flag scored lap. This partial lap will count toward the event's total number of laps.
- f) A lap will not be scored on the original start and/or any restart unless all cars complete the lap by passing through the start/finish line, except for the cars involved in the incident.
- g) On all yellow & red flag stoppages, lapped cars will be placed at the tail.
- h) Any car deemed to have caused an intentional yellow because of a bad start, restart, becoming lapped, or in danger of being lapped, may be disqualified.

## **F) Payoff Procedures**

- a) All prize money will be mailed from Eldora to designee. Checks will not be issued without a verified IRS Form W-9 (or W-8BEN for Canadian entrants) on file. All entrants are participating on their own behalf and are completely independent of the event promoter. As an independent contractor, entrants are responsible for prize money received including all income and withholding taxes that apply to such winnings.

## **G) Alternate Starting Positions**

- a) In the event that a car qualified for the A-Main is unable to take the initial green flag, the first nonqualified car will be taken as the alternate for the A-Main event. However, Alternates earn the full amount of purse money that their respective finishing position is scheduled to pay. The original "A" qualified car will receive first non-transfer purse money from the B-Main.

## **H) Penalties, Fine Schedules & Protests**

Eldora Speedway expects its Competitors to conduct themselves in a professional manner at all times during any event and/or when representing the series. The team owners are solely responsible for the conduct of their drivers and/or team members and/or anyone connected to or affiliated with that owner's team. All fines that are listed in sub-section I are in regard to the initial penalty. Multiple infractions of the same type will increase the severity of the penalty.

### **1. Penalties and Fine Schedules**

- a) All fines may be collected from prize money on the day of the infraction or purse winnings may be withheld if a post-race inspection requires additional time to inspect the car, including, but not limited to sending tire samples to a laboratory for independent testing. If the competitor has not won appropriate money, the fine must be paid in full before the car and/or driver participates in another event at Eldora Speedway. Team owners are ultimately responsible for paying fines on behalf of all Competitors on their respective team.
- b) Any Competitor that attempts to and/or does physically abuse any event Official, including pushing, punching, touching, grabbing and/or grabbing the Official's equipment, etc., will be subject to disqualification and/or fine and/or suspension and/or legal action and/or any other action deemed appropriate by Eldora Million Officials. Maximum = \$5,000.
- c) Any Competitor that verbally abuses any Event Official will be subject to disqualification and/or fine and/or suspension and/or legal action and/or any other action deemed appropriate by Eldora Million Officials. Maximum = \$500.
- d) Any Competitor that attempts to push their racecar off from the wrong area and/or does not stop in the designated area as to cause undue confusion and/or delay will be subject to fine and/or suspension and/or any other action deemed appropriate by Eldora Million Officials. Maximum = \$500.
- e) Any Competitor who fails to stop for and/or allow post-race inspection will be subject to disqualification and/or fine and/or suspension and/or any other action deemed appropriate by Eldora Million Officials. Maximum = \$500.
- f) Any Competitor that attempts to and/or passes the pace vehicle (unless instructed to do so) will be subject to the loss of two (2) positions and/or disqualification and/or fine and/or suspension and/or any other action deemed appropriate by Eldora Million Officials. Maximum = \$100.
- g) Any Competitor that attempts to drive roughly and/or bumps another Competitor unnecessarily will be subject to disqualification and/or fine and/or suspension and/or any other action deemed appropriate by Eldora Million Officials. Maximum = \$5,000.
- h) Any Competitor that attempts to use illegal fuel will be subject to disqualification and/or fine and/or suspension and/or loss of points and/or any other action deemed appropriate by Eldora Million Officials. Maximum = \$5,000.
- i) Any Competitor that attempts and/or is found to be using tires that are found to be illegal in any manner will be subject to disqualification and/or fine and/or suspension and/or loss of points and/or any other action deemed appropriate by Eldora Officials. The minimum penalty will be as follows; disqualification from the Event and loss of all earned purse and/or award money from the Event.

- j) Any Competitor that attempts to or uses an illegal motor will be subject to disqualification and/or fine and/or suspension and/or loss of points and/or any other action deemed appropriate by Eldora Million Officials. Maximum = \$5,000.
- k) Any Competitor that fails to quickly stop for a red flag or drives through the incident area will be subject to a loss of two (2) positions penalty and/or disqualification and/or fine and/or suspension and/or loss of points and/or any other action deemed appropriate by Eldora Million Officials. Maximum fine: \$500.
- l) Any Competitor that goes into another Competitor's pit area or to another Competitor's car and becomes involved in any type of altercation will be subject to disqualification and/or fine and/or suspension and/or loss of points and/or any other action deemed appropriate by Eldora Million Officials. Maximum = \$5,000.
- m) Any Competitor involved in an altercation that results in physical contact will be subject to disqualification and/or fine and/or suspension and/or loss of points and/or any other action deemed appropriate by Eldora Million Officials. Maximum = \$5,000.
- n) Any Competitor who drives a racecar in an area that is closed to racecar traffic or drives through the pit area at excessive speed with either a racecar, scooter or 4-wheeler will be subject to disqualification and/or fine and/or suspension and/or loss of points and/or any other action deemed appropriate by Eldora Million Officials. Maximum = \$500.
- o) Any Competitor who goes out onto the racing surface or any other controlled area including the infield when closed to Competitors without permission under a controlled period will be subject to disqualification and/or fine and/or suspension and/or loss of points and/or any other action deemed appropriate by Eldora Million Officials. Maximum = \$500.
- p) Any Competitor who ignores a flag or Official signal will be subject to disqualification and/or fine and/or suspension and/or loss of points and/or any other action deemed appropriate by Eldora Million Officials. Maximum = \$500.
- q) Any Competitor who is found to be in violation of the substance abuse policy at any event will be subject to disqualification and/or fine and/or suspension and/or loss of points and/or any other action deemed appropriate by Eldora Million Officials. Maximum = \$10,000.
- r) Any Competitor who exits their car onto any area where other cars are still moving will be subject to disqualification and/ or fine and/ or suspension and/or loss of points and/ or any other action deemed appropriate by Eldora Million Officials. Maximum= \$500.
- s) Any Competitor that publicly criticizes the Eldora Speedway via social media, including re-tweets (Twitter, Facebook, etc.) or thru quotes given to news reporters will be subject to a fine. Maximum = \$500.

## **2. Protests**

- a) All protests must be turned into the Eldora Million Director within five (5) minutes of the posting of the official finish.
- b) The protest filing fee and protesting fee must be paid at the time of the protest.
- c) Only the car owner, the driver and/or the designated team representative of the car owner may turn in an official protest.

- d) Any refusal of inspection and/or non-compliance during an official protest will result in the disqualification of the protested car and the prescribed penalties.
- e) If the car protested is found legal, the protesting fees will be released to the protested team less the protest filing fee.
- f) If the car protested is found to be illegal, the protesting fees will be returned to the team filing the protest less the protest filing fee.
- g) Any altercation relating to the incident with Officials and/or any other racing participants by the team filing the protest will nullify the objection.
- h) PROTESTING FEES: (Figures in parentheses are protest filing fees): Motor tear down involving heads off and cylinders inspected; \$750 (\$75): This allows the inspector to inspect block only. Weight will be \$750 (\$75) and the protest must be made prior to the protested car crossing the scale. P&G Tests, fuel test including chemical analysis and all other technical protests; \$500 (\$50).
- i) TIRE PROTESTS: Tire protests may involve one and/or both rear drive tires. The protest fee will be \$750 per tire and a protest filing fee of \$75. The protest will require the submission of the protested tire(s) by the car owner, driver and/or designated representative which has filed the protest. The tire(s) involved in the protest will be shipped, processed and chemically analyzed at a facility designated by Eldora Speedway. The determination of the facility will be final and non-appealable.
- j) The Eldora Million Officials reserve the right to ask for a legality test at any time (sealed motor and/or otherwise). If through testing procedures a car is found to be illegal, responsibility for proving otherwise is solely with the team that was checked. There will be no exchange of money for tests asked for by Officials when a formal protest is not turned in.
- k) The Eldora Million Officials reserves the right to accept or deny any protest based on their sole discretion. 'Grudge' protests and/or any protest that are 'not in the spirit of good standing' will be denied.

## **I) Car Rules**

ANY CAR, TEAM AND/OR DRIVER THAT DOES NOT MEET THESE SPECIFICATIONS AND/OR EQUIPMENT REQUIREMENTS WILL BE SUBJECT TO PENALTIES AS DETERMINED BY THE ELDORA OFFICIALS.

### **1. Engines**

- a) Only small block V-8 engines with the cam in the block and a maximum of 410.00 cubic inches of displacement (tolerance + 0.000) will be permitted. The formula  $6.2832 \times \text{bore}^2 \times \text{stroke}$  will apply. Big block engines will not be permitted.
- b) The engine must be mounted in-line with the driver and the drive-line must pass beneath the driver on center through the driver compartment. Offset engines and/or offsetting the position of the engine will not be permitted.
- c) The engine block and cylinder heads must be machined from cast aluminum. Billet machined blocks and/or cylinder heads will not be permitted.
- d) Engines with the magneto and/or distributor in a forward mounted and/or front mounted position will be allowed but must be approved prior to competition. Engines with the magneto and/or distributor mounted in the stock OEM production position for the block and/or engine must be approved prior to competition.
- e) Approved Front Drive Magneto System: Moroso 60205 & 60206.
- f) Only normally aspirated engines will be permitted. Turbo chargers, super chargers and/or forced induction of any type and/or description will not be permitted.
- g) The maximum engine cylinder bore size shall be 4.165 inches.
- h) All engine cylinder sleeves (inserts) must be machined from an iron and/or steel alloy.
- i) Titanium crankshafts, connecting rods and/or rod caps will not be permitted.
- j) Only two (2) valves and one (1) spark plug will be permitted per cylinder.
- k) Cylinder heads must retain a traditional valve pattern. Rotation of the valves will not be permitted. Canted or splayed valve cylinder heads must be approved prior to introduction into competition.
- l) Only steel connecting rods with a maximum length of 6.000 inches will be permitted.
- m) All oil pans must have an inspection plug. The inspection plug must be a #12AN fitting or 1.00 inch pipe plug.
- n) In the event that an engine does not have an inspection plug the oil pan must be removed for inspection prior to competition.
- o) Only throttle plate (butterfly) and shaft throttle body styles with round circular bores will be permitted. The maximum throttle bore as measured at the throttle plate (butterfly) may not exceed 3.000 inches in diameter. Slide plate, rotary cylinder, and/or other styles will not be permitted for competition. Carbon fiber manifolds and/or any other injection type pieces manufactured from carbon fiber will not be permitted.



- p) A maximum of 16 fuel nozzles, utilizing two (2) per cylinder will be permitted. One (1) nozzle must be placed in the cylinder head and one nozzle must be placed in the injector.
- q) A minimum of two (2) throttle return springs must be used to mechanically return the throttle to a fully closed position.
- r) Only magneto-type ignitions will be permitted. A single (1) crank-trigger type system will be permitted as a backup ignition system. One (1) single switch that alternates the current between the magneto and the crank trigger only may be mounted to the dashboard within the driver's reach. Only 2-way, on-off type switches will be permitted. Multiple coil-pack ignitions will not be permitted.
- s) Steel and stainless steel headers will be permitted. Titanium headers will not be permitted.
- t) New engine components and/or new engine configurations must be submitted and approved by Eldora Speedway.
- u) If an engine is inspected and it measures over 410.00 cubic inches, the driver and the car will be disqualified. All earned points and money will be forfeited for that Events. NOTE: The engine may be checked at any time during an event or torn down after the event at the discretion of Eldora Officials. If an Eldora Official finds the motor to be illegal, the competitor will be given the opportunity to remove the cylinder head for clarification purposes. There will be a one hour time limit set for this process following the conclusion of the A-Main.
- v) An engine conforming to the Alternative 410 Motor Program (A4MP) will be permitted in the Events.
- w) The rules and specifications for this program are available at: [www.alternative410motor.com](http://www.alternative410motor.com)
- x) All winnings will be held until the motor is determined to be legal by means outlined at: [www.alternative410motor.com](http://www.alternative410motor.com)

## **2. Fuel**

- a) Fuel additives, including but not limited to nitro, nitro methane and/or nitrous oxide injection will not be permitted. Pure methanol and/or other approved fuels will be permitted. Fuel samples may be taken from time-to-time for inspection and analysis.
- b) The same fuel cell/tank must be used in the same car for the entire race program. The fuel cell/tank may be changed at the discretion of Eldora Officials if the cell/tank has been contaminated and/or physically damaged for any unforeseen reason.
- c) A fuel cell with bladder and foam will be the only type fuel cells permitted. The fuel cell must be of one piece construction of cross-link polyethylene plastic. Alterations and modifications will not be permitted.
- d) All teams racing at the Events will be encouraged to run a 33 gallon fuel tank and bladder. At the Events, 33 gallons of fuel will be considered as part of the formula utilized when determining the total time prior to refueling in any specified and/or announced event.

## **3. Muffler and Sound Reduction Devices**

- a) Only the Schoenfeld (part # 14272735-78) or P1 Australia (part # SSM5C) muffler will be permitted. The specified muffler must remain unaltered from the manufacturer and are mandatory at all tracks that require mufflers.

- b) All mufflers must be securely mounted. Mufflers that are mounted with pop rivets and/or sheet metal screws will not be permitted.
- c) Any muffler changes after the car has been through inspection will not be permitted. Mufflers used in qualifying must be used through the entire racing program. The only changes that will be permitted will be at the discretion of Eldora Officials. Physical damage from a crash and/or other incident will permit a change, but then the car must be inspected again.
- d) The mufflers must remain attached to the headers at all times. All muffler and header components must remain intact and operating. If the muffler becomes disconnected from the header and/or fails to operate it could result in disqualification from that race. If the muffler and/or header is damaged from and/or altered from track debris, a crash and/or a physical defect and/or no muffler components were lost and/or missing the penalty will be at the discretion of the Eldora Officials.
- e) Any muffler and/or header that has been altered in an attempt to gain a competitive advantage will not be permitted into competition and could result in disqualification.
- f) All muffler rules and/or decibel (DBA) constraints are subject to state and local regulations. In addition, monitoring by Eldora Officials will aid in enforcing the rules and regulations of those agencies.
- g) When qualifying, any car determined to be in excess of the Decibel limit(s) set by either the track and/or any local agency, will receive only one (1) lap of qualifying at the end of time trials and the highest qualifying position the car may achieve is the first position behind the invert. If the car pulls off and no time is recorded, the car will be permitted one (1) lap at the end of time trials. If during that attempt the car remains louder than the limit it will result in an automatic disqualification.

#### **4. Traction Control Devices**

- a) Traction control devices of any type are not permitted at any time, during any event.
- b) Any team found with a traction control device in pre and/or post-race inspection shall be disqualified from that event. Additional penalties, including indefinite suspension and/or fines, and/or any penalty deemed appropriate by Eldora Officials may be issued.
- c) From time-to-time random inspections will occur and various components may be impounded for further analysis and inspection including, but not limited to ignition systems, ignition boxes, wiring looms and/or tachometers.
- d) The Xtreme 30 sparkbox version #2 both long & short is LEGAL. The Xtreme 30 sparkbox version #3 both long & short is ILLEGAL. Check with manufacturer for correct and legal application.

#### **5. Chassis/Frame**

- a) All chassis/frames built during and/or after the 2005 season should have a manufacturer's serial number and identification plate visible and welded on the left front side of the roll cage upright.
- b) Roadster type chassis will not be permitted. Slip-tubing is not allowed in the chassis construction. This includes safety bars. Any existing slip-tubing must be replaced or welded. Clamped or bolted slip tube joint will no longer be allowed.
- c) The chassis must have a minimum of six (6) mounting points for securely mounting any manufacturer's seat per the seat and chassis manufacturer's specifications.

- d) Drag links must be made of 4130 steel a minimum of one (1) inch in diameter and a minimum material thickness of .058 inches. Drag links, Tie Rods, and Left Front Radius Rods must be 4130 steel with magnetic steel rod ends. Swedging of the tubing will not be permitted. The drag links must be tethered to the frame with a minimum of one (1) inch nylon webbing.
- e) Hollow and/or drilled bolts, fasteners, and/or heim joints (rod ends) will not be permitted.
- f) Only front axles made of magnetic steel will be permitted. Approved axle dimensions are:  
 2-1/4" x 0.120"  
 2-3/8" x 0.095"  
 2-1/2" x 0.095"  
 Larger thicknesses may be approved at the Eldora Official's discretion.
- g) Titanium front axles, nerf bars and/or rear bumpers will not be permitted. Nerf bars and rear bumpers must be made from magnetic steel and/or stainless steel. The bumpers must be a minimum of one (1) inch in diameter and have a minimum material thickness of .065 inches. The nerf bars must not extend past the outside edge of the tires. All left and right side nerf bars must attach to the chassis at 3 points. 2 point side nerf hoops will no longer be allowed. For any car to be pushed off at any time the rear bumper must be in place behind the tail tank.
- h) All axle tethers will be required to attach to the front engine plate post or the rear bolt of the front radius rod and not the radiator post.
  - i) Approved front axle tether systems are mandatory. The tether mounting must meet the SFI 55.1 specifications which includes two (2) Vectran® HS V-12, or Dynemma 12 tethers attached to the chassis. Tether systems must include a "king pin to king pin" tether that will attach to the axle clamp/band. Tether systems should be installed using the manufacturer's provided fasteners. Tether systems of any type must be pre-approved and installed in accordance with the manufacturer's instructions. 2019 was the last year "bolt to bolt" radius rod axle tethers were allowed. Beginning in January 2020, all axle tether systems required clamping to or wrapping around the axle per the manufacturer's instructions. The approved axle tethers may be revised from time-to-time with additional approvals and/or other changes to the approved list.
- j) All radius rods shall be constructed as a solid piece of round tubing with provision for a rod end on each end. No addition to the radius rod will be allowed. Radius rods must be attached to the frame and axle in a stationary manner. Devices that are designed to change the length or position of the radius rod in any way while the car is moving will not be allowed.
- k) LF radius rods are to be made of 4130 steel with steel rod ends.
- l) The front bumper must not extend more than eight (8) inches from the frame and/or the measurement from the center of the front axle to the front of the front bumper must not exceed 23.5 inches.
- m) The top of the roll cage shall have a maximum outside width of 29.5 inches. Bracing that would prevent the driver's ability to exit through the opening and/or inhibit safety/rescue workers ability to extract the driver will not be permitted.
- n) The cockpit horizontal middle frame bar will have a maximum outside width of 32.0 inches.
- o) The bottom frame rail will have a maximum outside width of 26.5 inches.
- p) All tubing utilized in the construction and/or fabrication of the main frame must be round in shape. Any other shapes, such as elliptical (oval) tubing will not be permitted.

- q) Only steel, carbon fiber or aluminum floor plans will be permitted.
- r) The minimum wheelbase will be 83 inches. The maximum wheelbase that will be permitted will be 90 inches.
- s) Front anti-roll torsion bar assemblies (sway-bars) will not be permitted.
- t) All cars must have a driveline strap and/or a driveline hoop restraint constructed of a minimum of .065 inch magnetic steel either welded and/or bolted to the chassis. The rear cross member used for mounting the steel driveline hoop must be constructed of .083 inch steel.
- u) Wings, bumpers and/or nerf bars must be positively fastened with bolts & nuts, hitch pins and/or roll pins only.
- v) The only chassis and/or frame adjustable device will be one (1) top wing adjuster for the top-wing slider mechanism. The slider must be one dimensional and allow forward and rearward movement only.
- w) The following frame measurements are minimum dimensions. Only those areas indicated are mandatory and subject to technical inspections. In lieu of the "BUTT" BAR a car's rear end can be tethered to the rear chassis. ASTM4130 normalized steel or equivalent material is suggested. See drawing 16.5 A,S.

TOP RAILS 1-1/2" x .095"

BOTTOM RAILS 1-3/8" x .095" or 1-1/2" x .083"

ROLL CAGE UPRIGHTS 1-3/8" x .083"

ROLL CAGE CROSSMEMBER 1-1/2" x .095"

UPPER RAILS 1-3/8" x .083"

REAR END SAFETY "BUTT" BAR 1" x .083" or 1-1/4" X .065"

BRACE 1-1/4" x .065"

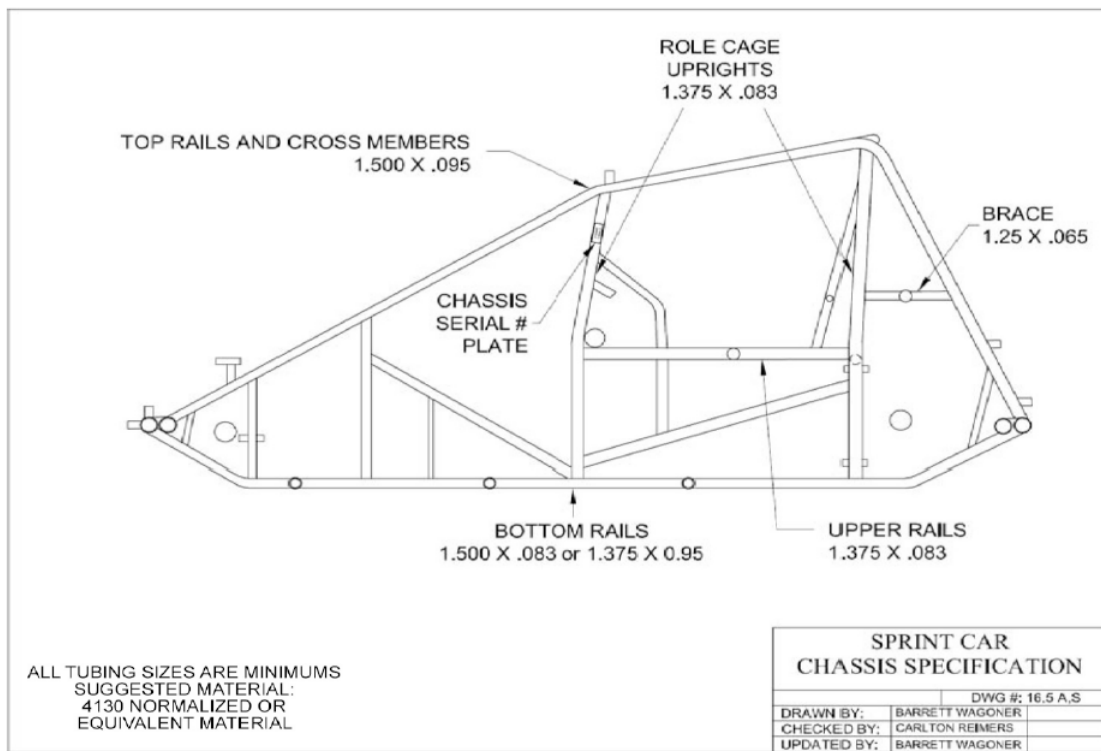

- x) Torsion arm stops will be mandatory on both sides of the front torsion bars. The retainer may be of the rod-type with a securing cap or insert with an expanding mandrel and/or any other approved Torsion arm stop design. Torsion arm stops must be installed and used in accordance with the manufacturer's instructions.

The following torsion bar stops(s) have been approved for competition:

Moose Block 1200 Retainer Kit

All Star Performance All Star 10730 Retainer

Maring Safety Retainer

Butlerbuilt Mandrel

KKR grove and clip

Kaeding Clip

DMI – T-REX (Torsion Restraint Express System)

Schroeder Part number "BARS" (for Schroeder bars with relief in ends)

Schroeder Part Number: "RWLAR" (Wedge Lock)

The approved Torsion Arm Stop may be revised from time-to-time with additional approvals and/or other changes to the approved list.

- y) Chassis Support Bars: Beginning in 2019, all chassis were required to have additional bars installed to support and decrease the span between the front and rear uprights in the driver's area. The new support bars must be in addition to the front and rear uprights. Any attempts to manipulate the front and rear uprights to conform to these measurements will not be allowed at the discretion of Eldora Officials.

These additional bars will be a minimum 1.375" x .083" ASTM4130 normalized steel or equivalent material.

Left and right side support bars may be one of the three designs below.

Left and right side support bars do not have to be of the same design.

Right side body opening shall remain the same 10 inches vertical and 21 inches horizontal at any point, with the exception of the 1-3/8" support tubing in place.

Left and right side support bars may be one of the three options:

1. Support bar may be designed similar to what was known as a "safety bar." It must be attached to the top rail at a point 15 inches to 20 inches from the rear of the front upright. It must attach to the hip rail and have a gusset attached to the rear upright near a point opposite of the rear brace/shock mount bar. The curve must be between 4 inches and 7 inches measured from outside of the rear upright tube to the outside of the support bar. See drawing 16.12.1.
2. Existing chassis with a left side support bar installed (formerly called safety bar) that do not meet the option one specification above, may add a gusset that attaches to the top rail 15 inches to 20 inches from the rear of the front upright and angle to the support bar. The existing support bar tubing must meet the minimum as described above 1.375" x .083" ASTM4130 normalized steel or equivalent material. See drawing 16.12.2.
3. A support bar may be added to the top rail at a point 15 inches to 20 inches from the rear of the front upright and to the rear upright near a point of the rear brace / shock mount bar but no higher than 7 inches above the hip rail. This bar may have a slight curve near the rear upright to accommodate elbow room and ease of fitment. See drawing 16.12.3.

#1 Support Bar

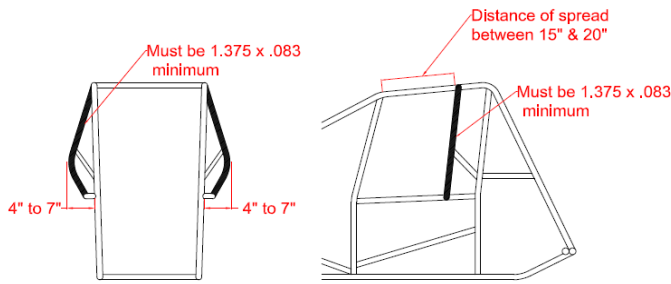

Diagram 16.12.1  
By Tom Devitt

#2 Support Bar

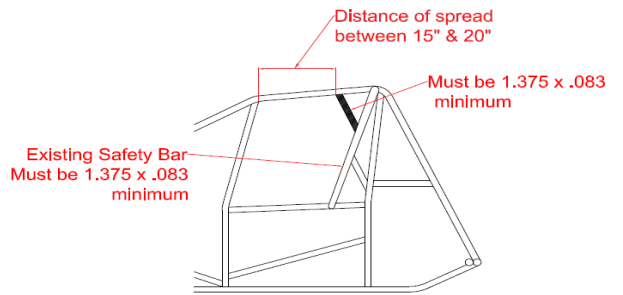
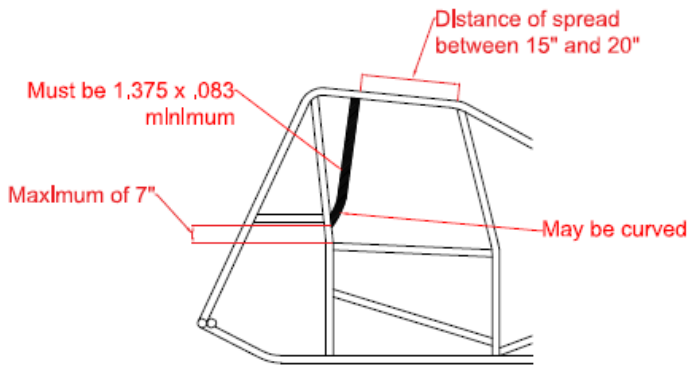
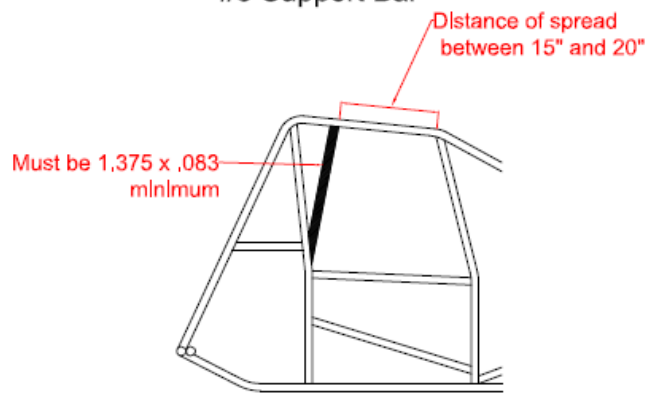

Diagram 16.12.2  
by Tom Devitt

#3 Support Bar Curved Option



#3 Support Bar



Drawing 16.12.3  
By Tom Devitt

## 6. Weight

- a) All racecars must weigh a minimum of 1425 pounds with a driver fully prepared to compete in the car throughout an entire event.
- b) Additional bolt-on weight will be permitted, but must be mounted and fastened to the frame and/or chassis in a secure manner. All additional bolt-on weight must be mounted and fastened in the area between the bottom frame rails and axles but mounted no higher than the upper rails. At the discretion of Eldora Officials additional bolt-on weight may be mounted and/or fastened forward of the front axle, but not past the front torsion bar. All bolt-on weight must be painted white.

## 7. Body

- a) Only standard type Sprint Car bodies, tails and hoods will be permitted.
- b) Side foils, rudders and/or panels that extend beyond the rear of the cage support bars will not be permitted.
- c) Nose pieces and/or the top portions of the hood must not extend forward of the leading edge of the front torsion tube or similar position on a coil-over car. Torsion tubes must be positioned in what is considered a

conventional location. The hood side paneling or other side body pieces must not extend forward of and/or below the front axle.

- d) Sunshields are permitted. Sunshields cannot extend beyond the down tubes of the car or restrict the driver's vision, restrict driver's exit, or direct air all at the discretion of the Eldora Officials. The maximum height is 9 inches and no dish visors or wicker bills are allowed.
- e) Wedges and/or foils underneath the racecar will not be permitted.
- f) Pieces that are added to the basic frame to resemble, imitate and/or be specifically designed to deflect, trap and/or form a pattern for air to travel in a directed manner, except for those used to cool and/or protect the motor and the brake system, will not be permitted.
- g) Mirrors of any kind, whether attached to the racecar and/or the driver, will not be permitted. All cars must have a minimum of an 18 inch tall number on the outside of both top wing panels and a minimum 18 inch tall number on the top wing center foil. Any letter utilized as part of the car number must be a minimum of 12 inches tall. If there are cars at any event that carry duplicate car numbers then one of the two cars will be required to add a letter to the number for scoring purposes.
- h) All cars will be required to run a full sprint-type appearing hood with a maximum outside hood width of 30 inches. The hood must extend to the front of the torsion tubes and/or similar location on coil-over cars. The hood may be a multiple piece design, but visually, it must appear to be one continuous piece in side-to-side and front-to-back manner.
- i) The driver's right side opening must be a minimum of 10 inches vertical at any point and a minimum of 21 inches horizontal at any point. See Drawing 16.7.J. The left side paneling may extend to but not forward of the support bar. See Drawing 16.7.K. The use of a left side arm guard as part of the paneling is acceptable as long as it or any other part of the paneling does not prevent left-side driver entry or exit at the discretion of Eldora Officials.

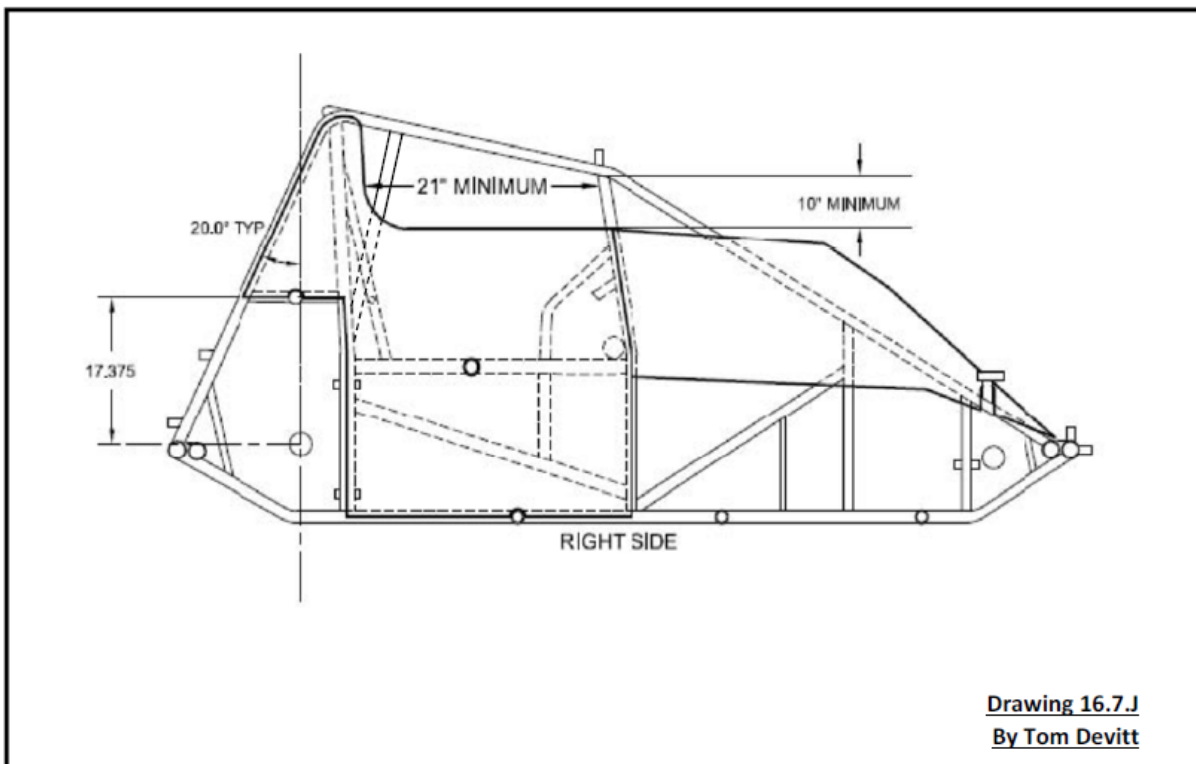

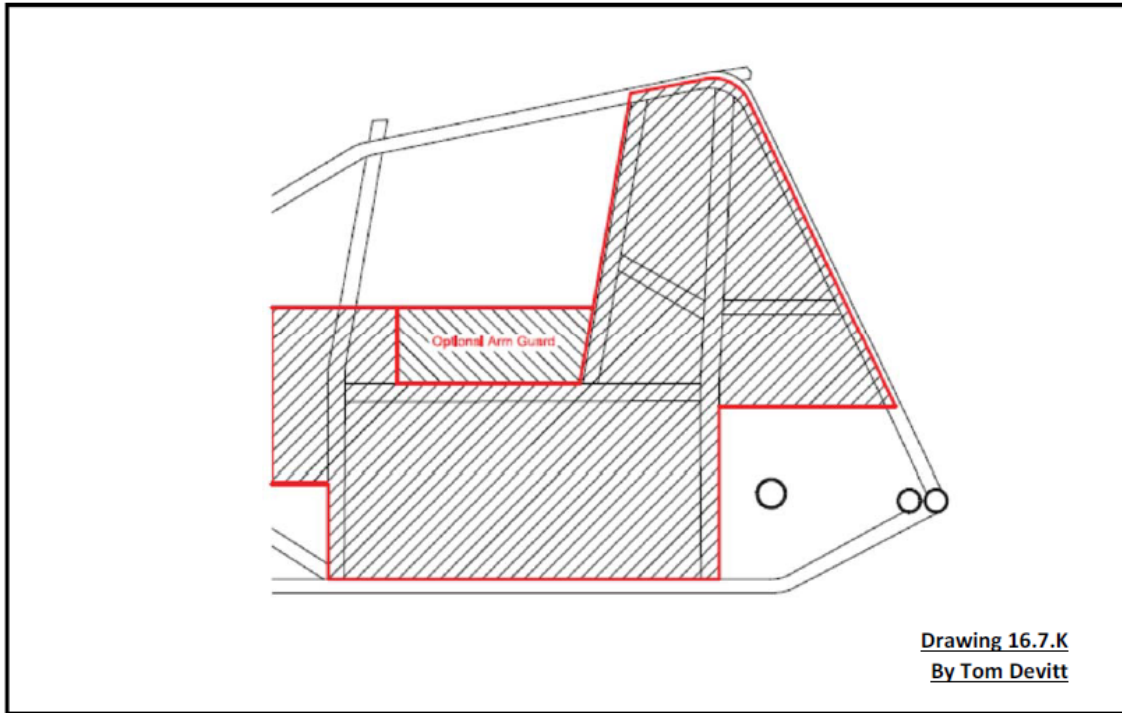

- j) Safety bar(s) and/or arm guard paneling that protrude outward from the frame rails for the purpose of creating room for the driver will be permitted. The guard(s) and/or paneling will be permitted to extend a maximum of 7 inches as measured from the outside edge of the middle frame rails and must remain above the middle frame rail. The sole purpose of this area is creating elbow room for the driver. The elbow room must remain above the upper “middle” frame rail and may not extend rearward of the leading edge of the rear axle.
- k) Rear radius rod protectors will be permitted. The maximum protector vertical opening will be 10 inches in height by 24 inches long and it must not extend more than 3-1/2 inches from the outside edge of the bottom frame rails.
- l) A maximum 1-1/2 inches wide by 20 inches long exhaust fume deflector, located on the bottom side-body panel at the rear edge will be permitted. The turnout angle must not exceed 90 degrees.
- m) All other side paneling must be fabricated flat and must not extend past the outside edge of the frame rails more than the thickness of the paneling material.
- n) Side body panel designs and/or concave surfaces that, in the sole discretion of the Eldora Officials, are intended to trap, alter and/or direct airflow for the purpose of gaining an aerodynamic performance advantage will not be permitted.
- o) Any new body designs including, but not limited to side body panels, hood design, nose pieces and/or any other part of the exterior body must be approved by the Eldora Officials prior to being introduced into competition.

## 8. Wings

### a) Top Wing Center Foil



- i. Center Foil maximum size of 25 square feet with a maximum depth/thickness of 9 inches and a maximum length of 60 inches. Center Foil must be square or rectangular in shape with all 4 corners set at 90 degree angles with no variance allowed. Center foil top is to be flat from front to back and side to side. The center foil top must start being flat within 6 inches from the center foil's front leading edge. See Drawing 16.8.1.E at the end of this document.
- ii. Center Foil shall be fully sheathed in aluminum. Vent holes, dimples, ridges and/or any other type of fabricated modification will not be permitted anywhere on the wing.
- iii. A maximum 2 inches removable wicker bill may be mounted on the rear edge of the center foil. Wicker bill must be 90 degrees to the top of the center foil. Built-in wicker bills or gurney lips will not be permitted. The maximum dimension of wicker bill may change periodically at the discretion of Eldora Officials. Any such changes will be issued in writing prior to the event in which the change will be made.
- iv. The top wing may be adjustable in the cockpit by the driver. Other than the slider mechanism, moving parts will not be permitted on or in the foil structure.
- v. Only one slider mechanism will be permitted on the top wing, which only permits forward and backward adjustment.
- vi. Underneath side of center foil must appear to be a continuous smooth arc with no recesses, concaves, or protrusions. Center Foil must be one piece construction. Split or bi- wings will not be permitted. Only wings fabricated of metal alloys will be permitted. Fiberglass, carbon fiber and/or other similar material(s) will not be permitted in the basic framework of the wings. The top wing must not extend beyond outside of rear tires.
- vii. Foils or rudders will not be permitted anywhere on the top wing.
- viii. Wing T-Post will be built from 1" x .083" minimum ASTM4130 normalized steel or equivalent material. Wing attachment designs will be subject to approval. The only cast pieces approved will be HRP Part #HRP8811-A75-HD. If new T-Post designs are developed they must be submitted for approval. See Drawing 16.13.1.

### Wing T-Post

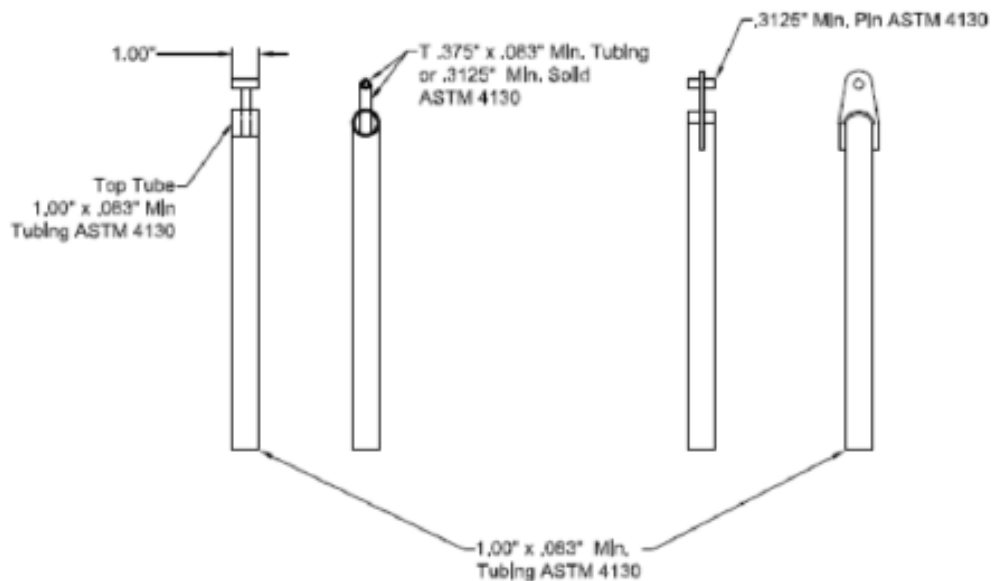

**b) Nose Wing Center Foil**

- i. The center foil will have a maximum size of 6 square feet with a maximum width of 36 inches and a maximum length of 24 inches. The center foil must be square or rectangular in shape with all four corners set at 90 degree angles. See Drawing 16.8.2.K at the end of this document.
- ii. Center foil shall be fully sheathed in aluminum. Vent holes, dimples, ridges and/or any other type of fabricated modification will not be permitted, anywhere on the wing.
- iii. A maximum 2 inch removable wicker bill may be mounted on the rear edge of the center foil. The wicker bill must be 90 degrees to the top of the center foil. Built-in wicker bills or gurney lips will not be permitted. The maximum dimension of wicker bill may change periodically at the discretion of Eldora Officials. Any such changes will be issued in writing prior to the event in which the change will be made.
- iv. The maximum distance from the center foil front edge to the front edge of the front axle may not exceed 20 inches.
- v. The center foil front edge must remain at least 1 inch behind the front edge of the front bumper. The center foil top surface from side to side must remain flat.
- vi. The center foil must be one piece. Split or bi-wings will not be permitted.
- vii. Only wings fabricated of metal alloys will be permitted. Fiberglass, carbon fiber or other similar material(s) will not be permitted in the basic framework of the wings.
- viii. The nose wing must not extend beyond the outside of front tires. The nose wing may not be cockpit or driver adjustable while the car is stationary and/or in motion.
- ix. Moving parts will not be permitted on or in the foil structure. Rudders or fins will not be permitted.
- x. The 5 inch section located at the rear of the front foil must not have a belly/curl arc that is out of proportion with the rest of the front foil. As measured on a 5 inch straight edge, the belly at 2-1/2 inches from the rear of the foil may not be deeper than 3/8 inch with no tolerance. It is suggested that the wing blue print specify 11/32 inch depth, so that if any deflection or movement of the wing occurs, the depth will not exceed the 3/8 inch specification. (This 3/8 inch measurement ensures that the belly/curl arc is gradual).
- xi. The belly/curl arc must span the entire length of the front foil and appear to be a gradual arc with the deepest point, not further back than 12 inches from the leading edge. The belly/curl arc must start at the front foil's leading edge and shall not exceed a depth of 2 inches. Front foil thickness cannot exceed 3.6 inches.

**c) Side Board Panels**

- i. All braces or supports shall be oriented thin edge to face the air stream. Only rectangular, round or oval metal braces not exceeding 1 inch in width will be permitted. Adjustable bracing will not be permitted.
- ii. Aero elliptical brace material will not be permitted.

- iii. Brace or support shall not resemble a wicker bill or a split wing Side boards must be mounted square to the center foil and parallel to each other. Any kick-out will not be permitted.

d) **Nose**

- i. The nose side board's maximum size will be 26 inches long and 12 inches tall with an overhang not exceeding 1 inch from the center foil front edge to the side board front edge.
- ii. Side boards may have a maximum 1/2 inch front, back, top and bottom turnout(s) (flange).

e) **Top**

- i. The Top wing side board's maximum size will be 72 inches long and 30 inches tall. The top 2/3's of each top wing side panel shall consist of only 2 corners. Each corner shall be set at a 90 degree angle with no variance. This portion of the side panel's leading edge may not be behind the center foils leading edge.
- ii. Panels must be of one-piece construction.
- iii. Panels must be fabricated flat. Turnouts on all edges of the wing must not exceed 1-1/4" x 1-1/4" and must be orientated at a 90 degree angle to the flat portion of the side panel. Both top wing side boards should be at a 90 degree angle from the center section at any point. If wing panel(s) become damaged, repairs must be made before the car can compete in the next event.

In the event that there are new wing/foil components and/or a new wing/foil configuration they must be submitted per the Eldora Million rule book prior to being introduced into competition for approval.

9. **Wheels/ Wheel Covers**

- a) The maximum width for the right rear wheel will be 18 inches. The maximum width for the left rear wheel will be 15 inches.
- b) The maximum wheel diameter will be 15 inches.
- c) Only steel or titanium wheel cover fasteners will be allowed.
- d) Plastic and/or carbon fiber wheels will not be permitted.
- e) Both 5 and 3 mounting point wheel covers will be allowed for competition under the following conditions. Starting with the 2017 racing season wheel covers having a minimum of 5 attachment points may continue to use dzus fasteners. Said dzus fasteners must be made of magnetic steel or titanium only. Wheel covers having only 3 attachment points must be bolted-on at all 3 points utilizing a minimum 5/16 inch, flanged magnetic steel or titanium bolt and an approved fastening (nut assembly) system.
- f) Optional fastening systems that are equal or superior to the above approved system will become available as the season opens and will be looked at for approval before competition.
- g) Approved fastening (nut assembly) systems:
  - Keyser Manufacturing, Part #100 7-101
  - Wehrs Manufacturing Part # WM377A-312 (Aluminum 5/16)

- Wehrs Manufacturing Part # WM377S-312 (Steel 5/16)
- Triple X Chassis Part # SC-WH-7810 (for a 1” spring)
- Triple X Chassis Part # SC-WH-7820 (for a 1-3/8” spring)

h) Digital air bleeders are allowed, but cannot be operated remotely. Air may not be introduced to the tire from any onboard system.

#### 10. Tires

a) Only the following designated Hoosier Racing Tires will be permitted for competition on all four (4) positions of the racecar at all the Events.

The tires listed immediately below will be required for the Events:

**Front:**

85/8.0-15                    D12, D15, D20

**Left Rears:**

15.0/92-15                    D12A  
 15.0/93-15                    D12A  
 15.0/94-15                    D12A  
 15.0/96-15                    D12A

**Right Rears:**

105/16.0-15                    D15A, Medium

- b) The altering of any tire compound, by any means, will not be permitted. Chemical alteration of the tread carcass and/or tread compound, such as tire ‘soaking’ and or the introduction of tread ‘softener’ and/or the physical defacement (removal, altering and/or covering) of tire sidewall markings in any manner will not be permitted. If any competitor is found to have altered their tires any penalty deemed appropriate by Eldora Officials may be issued. The rear drive tires may be protested by another competitor following the protest rules under Section I.2.
- Any tire may be inspected and/or analyzed for alteration at any time. This will consist of a process as determined by the independent laboratory that performs the analysis. A “Chain of Custody” process will be outlined with the competitor upon inspection of the tires.
  - The analysis process will require shipment of the tire to the selected laboratory. Additional race event(s) may be completed before a determination is made. If a penalty is issued, the event(s) that fell into the analysis time period while the tire(s) were being analyzed will be considered as part of the penalty time period.
- c) Rear tire dimensions must comply with the Eldora Speedway dimensions. Both rear tires must freely fit the Eldora Speedway Series gauges during pre and/or post-race inspection.
- d) During the RR Tire Enforcement Period, the right rear tire may only be changed to replace a punctured, damaged, sliced and/or out-of-round tire.
- e) Eldora Officials must be present when a marked and damaged right rear tire is replaced and/or a different right rear tire is fitted during the RR Tire Enforcement Period.
- f) **During Wednesday’s race night, the same marked right rear tire used in qualifying must be used for the A-Main, unless Eldora Officials communicate otherwise on race nights. The marked right rear tire must be purchased that same day from the Hoosier Tire Truck on-site. A maximum of two right rear tires may be purchased per entrant. Any legal right rear tire may be used for the start of the Heat, C-Feature or B-Feature events.**

- g) During Thursday's race night, right rear tires used in the heat race and A-Feature must be purchased that same day from the Hoosier Tire Truck on-site. A maximum of three marked right rear tires may be purchased per entrant. Any legal right rear tire may be used for the start of the D-Feature, C-Feature or B-Feature events.
- h) Any damaged right rear wheel may be replaced without penalty, but must utilize the same marked right rear tire. If the tire is flat and/or damaged then the rules governing the changing of the right rear tire must be adhered to.
- i) The front and left rear tires and/or wheels may be changed at any time between races.
- j) Defacing or altering, in any way, the tire manufacturers' brand name, logo and other tire compound/size information is not allowed.
- k) If a new right rear tire is fitted between qualifying and a heat race then that car loses its qualifying time and position and must race the rest of the program as a car that has posted no time in time trials.
- l) If a car loses a right rear tire on its first qualifying lap, a new right rear tire can be fitted, but the car will be restricted to one (1) lap at the end of qualifying and can qualify no better than one (1) spot out of the heat race inversion.
- m) During preliminary Main events, a flat and/or damaged tire may be changed during a caution period in the designated work area. The following rules apply to tire change during preliminary Main;
- i. The car will restart in the position and procedure of a car exiting the work area, behind all cars on the same lap, provided the replacement is made within work area time allowed.
  - ii. A replacement will only be allowed for damaged tires, flat tires and/or damaged wheels. This rule applies to all four (4) tires on the car.
  - iii. Prior to any work of replacement, positive approval for any replacement must be obtained from the Eldora Official assigned to the work area.
  - iv. A damaged tire is described as a tire; flat on the wheel, deflated, with extremely low air pressure or other circumstance. Loss of air must be due to an apparent puncture, hole, slice, cut, tread separation, extreme tire wear or similar situation.
  - v. The damaged tire can be replaced with a new tire of the same compound or harder.
  - vi. Damaged tires will be impounded by Eldora Officials for inspection.
  - vii. If any additional time is taken by the Eldora Officials to determine if the tire meets the damaged tire criteria, that time will be added to the work area time.
  - viii. A damaged wheel may also be changed, with a replacement tire, during a caution period in the designated work area under the same stipulations as stated in this sub-section n (i-viii). A damaged wheel is described as bent or broken, bead lock bent or broken, broken or damaged center section. Malfunctioning bleeder valves or bleeder devices are not considered as a damaged wheel.
- n) Replacing Marked Punctured, Damaged, Sliced and/or Out-of-Round Tires, with similar used Tires:
- i. During the RR Tire Enforcement Period, punctured, damaged, sliced and/or out-of-round marked right rear tires may be changed to a suitable right rear used tire of the same size and compound

without penalty. Cars changing to a used tire during the Heat race will restart the race at the rear of the field that is on the same lap. Replacement tires will be remarked by the Eldora Officials and the replaced tire shall be confiscated. Should a suitable used tire, as specified above, not be available a harder compound may be used at the discretion of Eldora Officials.

- ii. In the time period between time trials and the start of heat races a punctured, damaged, sliced and/or out-of-round marked right rear tire may be replaced with a new tire of the same size and compound without penalty. Replacement tires will be remarked by the Eldora Officials and the replaced tire shall be confiscated.

## 11. **Shocks**

- a) Only conventional and thru-rod style shock absorbers will be permitted. No additional components may be added to the torsion arm or other suspension components to help control the suspension. Only 1 shock per wheel will be allowed, a maximum of 4 shocks per car. Any new suspension configuration or new style shock configuration must be approved by Eldora Officials prior to being placed into competition. Performance, safety, cost, along with other variables, will factor into the approval process. It is recommended that the approval process be completed prior to product production.  
Approved thru-rod style shocks: Penske – Part # PS-7700T

## 12. **Other**

- a) Racing components in aluminum and magnesium should be checked for stress and replaced on a regular basis, based on the manufacturer's recommendations of the life usage of the part. These parts are, but not limited to, wheel centers, live rear axles, hubs and top wings.
- a) Computer operated and/or controlled parts, such as fuel injection, fuel systems, chassis adjusting systems, etc., will not be permitted at any time during any event. The use of any electronic remote and/or wireless equipment capable of adjusting any equipment and/or function on the race car during any type of racing competition will not be permitted.
- b) The use of electronic logic processors (this includes any traction control devices) to control any function of the racecar and/or any system for continuous gathering of data from any function of the race car for which the intended use is computer downloading will not be permitted at any time during any event.
- c) Two-way radios, crew-member to driver and/or any other means of electronic communication, other than the one-way radio provided by Eldora Officials, will not be permitted.
- d) All cars shall be equipped and/or be capable of being equipped with a transponder (for lap scoring). Transponders shall be located in any area determined by the Eldora Officials. The fitted transponder box shall be mounted as close as possible to the ground, but not protrude below the frame rail. It is the responsibility of the competitor to ensure that the transponder is in quality working condition, fully charged and is securely mounted and is in a suitable position with brackets as outlined above. Competitors may be required to leave their driver's license with Eldora Officials when they receive their transponder equipment. Should a team's transponder be lost, damaged, destroyed and/or not returned, the replacement cost of the transponder will be withheld from the team's purse winnings from that event. It is in everyone's interest that transponders are suitably and securely attached and are in good working condition.
- e) Competitors will be required to receive and use "one-way radio communication" from Eldora Officials. The communication from Eldora Officials will aid in the direction of the race, including, but not limited to, safety and resetting the race lineup prior to any restart.

f) Electronics, Gauges and Dashes

- i. 2-way communication devices in or attached to the race vehicle or on the driver's person will not be permitted.
- ii. Cellular, satellite and/or Wi-Fi devices in or attached to the race vehicle or the driver's person will not be permitted (including cell phones or smart watches).
- iii. Antennas will not be permitted in or attached to the race vehicle or carried by the driver.
- iv. All forms of a vehicle position system (GPS) will not be permitted.
- v. Only approved lap timing and or lap time recording devices (transponders) will be permitted.
- vi. Gauges to monitor engine conditions are permitted at the discretion of Eldora Officials.
- vii. All electric gauges, whether analog or digital, except tachometers, will only be permitted to have one (1) input from the respective gauge sensor. Outputs from the gauges will not be permitted. Tachometers will be permitted to record engine RPM for recall.
- viii. Electronic Dash Modules will not be allowed.
- ix. All additional wiring harnesses related to Electronic Dash Modules or any other type of data acquisition must be completely removed from the race vehicle during an event.

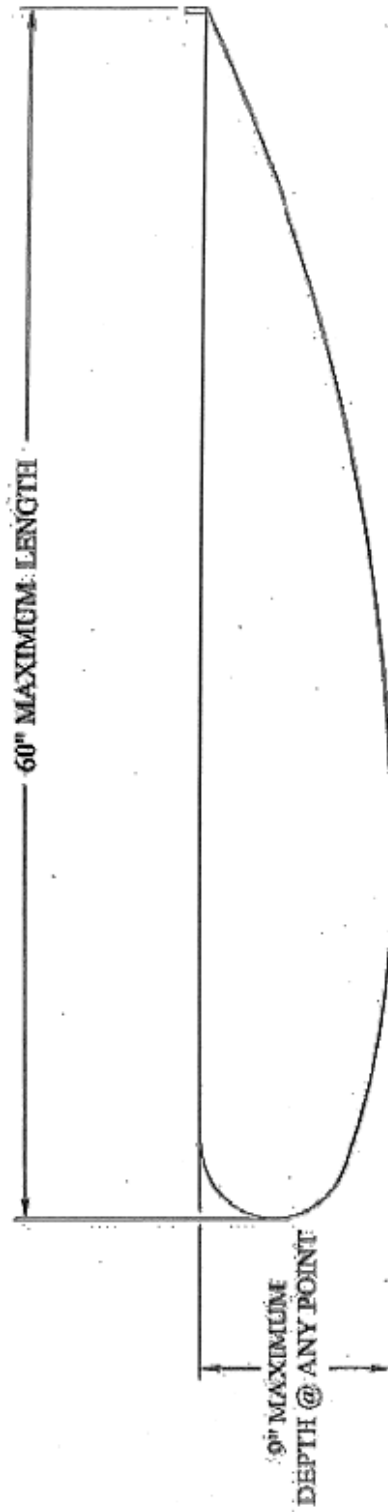

MAX. 2" WICKER BILL MAY BE MOUNTED ON REAR  
EDGE OF THE CENTER FOIL

SPRINT CAR  
TOP WING  
CENTER FOIL

DWG #16.8.1.E

DRAWN BY: BARRETT WAGONER

CHECKED BY: CARLTON REIMERS

UPDATED BY: BARRETT WAGONER



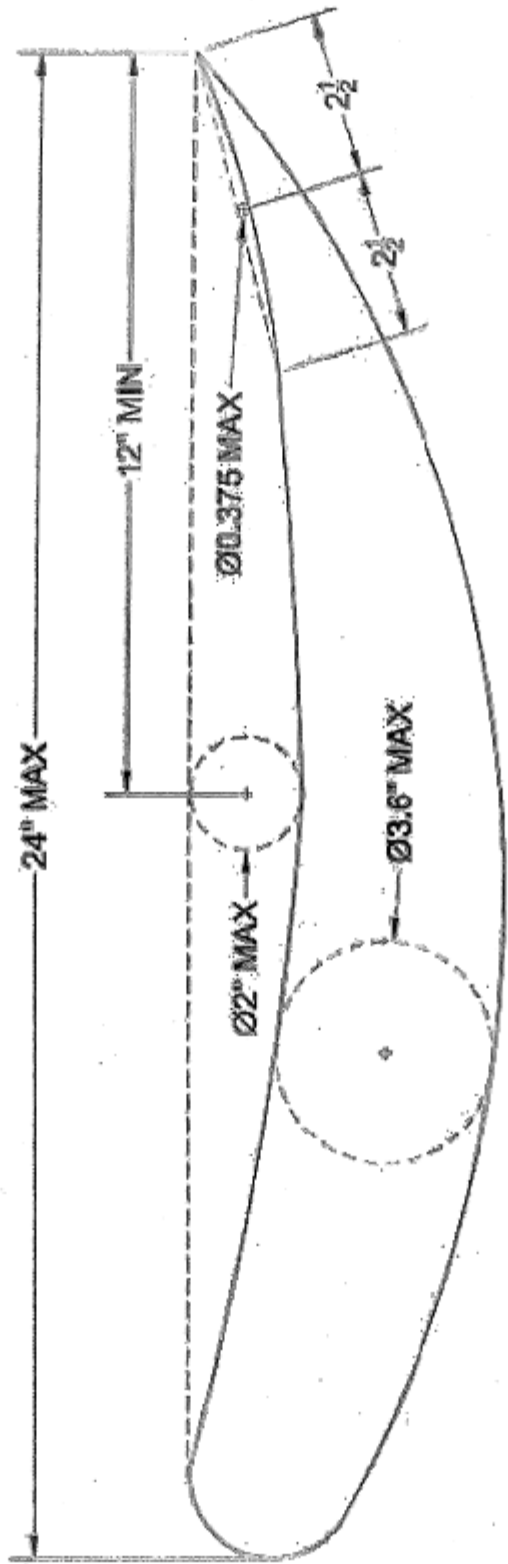

SPRINT CAR	
FRONT WING	
SPECIFICATION	
DESIGNED BY	PAUL S. BUECK
CHECKED BY	DAVID W. ...
DATE	...

2° WICKER BELL IS ALLOWED ON FRONT WING WITH FLAT TOP WING OPTION.